

JVC



**VIDEOGRABADOR
VIDEO CASSETTE RECORDER**

HR-J7004UM

ESPAÑOL

ENGLISH

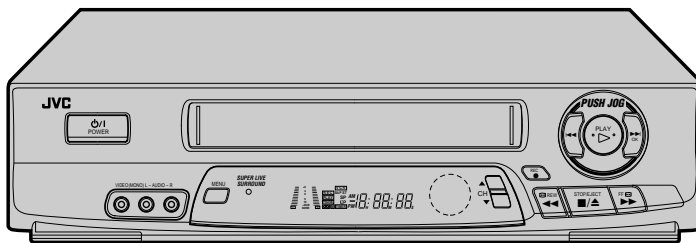

Hi-Fi **VHS**

MANUAL DE INSTRUCCIONES INSTRUCTIONS

For Customer Use:

Enter below the Serial No. which is located on the rear of cabinet. Retain this information for future reference.

Model No. **HR-J7004UM**

Serial No. _____

Dear Customer,

Thank you for purchasing the JVC VHS video cassette recorder. Before use, please read the safety information and precautions contained on this page to ensure safe use of your new VCR.

CAUTIONS

WARNING: DANGEROUS VOLTAGE INSIDE
WARNING: TO PREVENT FIRE OR SHOCK HAZARD, DO NOT EXPOSE THIS UNIT TO RAIN OR MOISTURE.

The POWER O/I button does not completely shut off mains power from the unit, but switches operating current on and off. "O" shows electrical power standby and "I" shows ON.

This unit is produced to comply with Standard IEC Publ. 65.

POWER SYSTEM:

This set operates on voltage of AC 110 – 220V~, 50/60 Hz with automatic switching.

Use the conversion plug (provided) depending on the type of your AC WALL outlet.

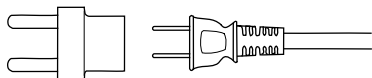

The rating plate and safety caution are on the rear of the unit.

IMPORTANT:

It may be unlawful to record or play back copyrighted material without the consent of the copyright owner.

CAUTION

- When you are not using the VCR for a long period of time, it is recommended that you disconnect the power cord from the AC outlet.
- Dangerous voltage inside. Refer internal servicing to qualified service personnel. To prevent electric shock or fire hazard, remove the power cord from the AC outlet prior to connecting or disconnecting any signal lead or aerial.
- Changes or modifications not approved by JVC could void user's authority to operate the equipment.

Warning on lithium battery

The battery used in this device may present a fire or chemical burn hazard if mistreated. Do not recharge, disassemble, heat above 100°C or incinerate. Replace battery with Panasonic (Matsushita Electric), Sanyo, Sony or Maxell CR2025; use of another battery may present a risk of fire or explosion.

- Dispose of used battery promptly.
- Keep away from children.
- Do not disassemble and do not dispose of in fire.

HOW TO USE THIS INSTRUCTION MANUAL

- All major sections and subsections are listed in the Table Of Contents on page 3. Use this when searching for information on a specific procedure or feature.
- The Index on pages 42–44 lists frequently-used terms, and the number of the first page on which they are used or explained in the manual. This section also illustrates the controls and connections on the front and rear panel, the front display panel and the remote control.
- The  mark signals a reference to another page for instructions or related information.
- Operation buttons necessary for the various procedures are clearly indicated through the use of illustrations at the beginning of each major section.

BEFORE YOU INSTALL YOUR NEW VCR . . .

. . . please read thoroughly the cautions on this page.



- Cassettes marked "VHS" (or "S-VHS") can be used with this video cassette recorder. However, only "VHS" recordings can be played back in this model.
- HQ VHS is compatible with existing VHS equipment.

I **NSTALLING YOUR NEW VCR** **4**

Basic Connections4

I **NITIAL SETTINGS** **5**

Plug & Play5

Clock6

Preparation6

Language Select6

Clock Setting7

Tuner8

Set Receivable Channels8

Add Or Delete A Channel10

S **IMPLE PLAYBACK AND RECORDING** **11**

Simple Playback11

Simple Recording12

P **LAYBACK AND RECORDING FEATURES** **13**

Playback Features13

Still Picture13

Slow, Reverse, Reverse Slow Or Fast-Motion

Picture13

Manual Tracking14

Super Live Surround14

Video Stabilizer15

Select The Soundtrack16

Superimpose17

Skip Search18

Repeat Playback18

Index Search18

Instant ReView19

Counter Reset19

Counter Memory19

Tape Position Indicator20

Next-Function Memory20

AV COMPU LINK Playback20

B.E.S.T. Picture System22

Preparation22

Recording23

Playback24

Recording Features25

Record One Program While

Watching Another25

Display Elapsed Recording Time25

Stereo And SAP (Second Audio Program)26

To Record SAP Programs26

T **IMER RECORDING** **27**

Instant Timer Recording (ITR)27

On-Screen Timer Programming28

Check And Cancel Programs30

Auto SP/EP Timer31

Auto Timer32

E **DITING** **33**

Edit To Or From Another VCR33

Control Two JVC VCRs33

Edit From A Camcorder34

S **PECIAL FEATURES** **36**

TV Multi-Brand Remote Control36

Cable Box Multi-Brand Remote Control37

Satellite Receiver Multi-Brand

Remote Control38

Q **UESTIONS AND ANSWERS** **39**

Playback39

Recording39

Timer Recording39

T **ROUBLESHOOTING** **40**

Power40

Tape Transport40

Playback40

Recording40

Timer Recording41

Other Problems41

I **NDEX** **42**

Front View42

Rear View43

Front Display Panel43

Remote Control44

S **PIFICATIONS** **45**

Basic Connections

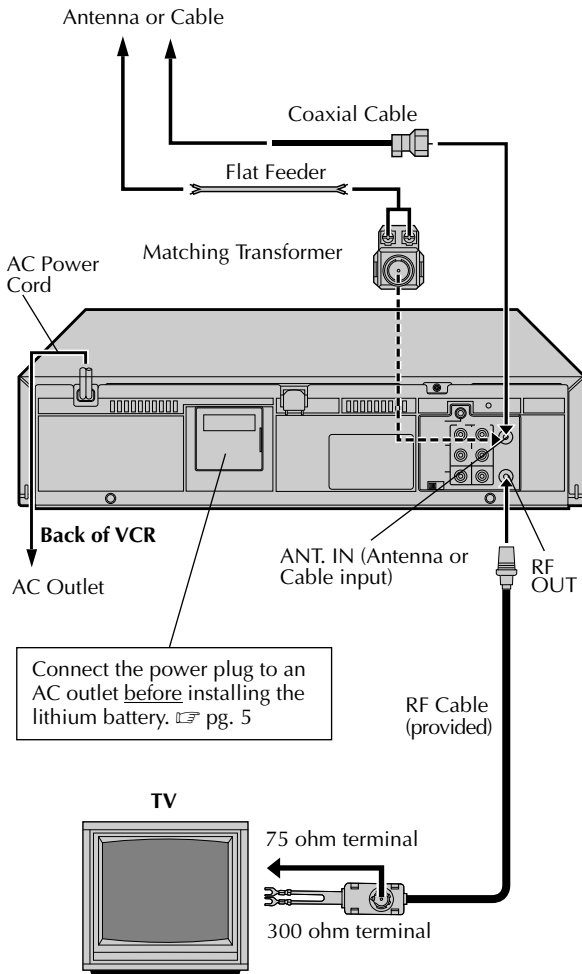

Back of VCR

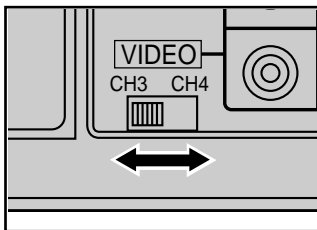

1 CHECK CONTENTS

Make sure the package contains all of the accessories listed in "SPECIFICATIONS" (pg. 45).

2 SITUATE VCR

Place the VCR on a stable, horizontal surface.

3 CONNECT VCR TO TV

The connection method you use depends on the type of TV you have.

RF Connection

- To Connect To A TV With **NO** AV Input Terminals . . .
 - Disconnect the TV antenna from the TV.
 - Connect the TV antenna cable to the ANT. IN jack on the rear of the VCR.
 - Connect the supplied RF cable between the RF OUT jack on the rear of the VCR and the TV's antenna terminal.

AV Connection

- To Connect To A TV With **AV** Input Terminals . . .
 - Connect the antenna, VCR and TV as shown in the illustration.
 - Connect an Audio/Video Cable (not supplied) between the AUDIO OUT and VIDEO OUT jacks on the rear of the VCR and the AV IN jacks on the TV.

4 CONNECT VCR TO POWER SOURCE

Connect the power plug to an AC outlet.

5 FINAL PREPARATION FOR USE

Select the VCR channel (3 or 4) by setting the switch on the rear of the VCR as shown in the illustration.

Turn on the power to the TV. You are now able to perform simple playback (pg. 11) and recording (pg. 12).

NOTES:

- The VCR channel is the channel on the TV which will display the audio and video signals from the VCR. The VCR's CH3-CH4 switch sets the VCR channel to CH3 or CH4.
- The CH3-CH4 switch is preset to the CH3 position. Set to CH4 if CH3 is used for broadcasting in your area.
- If your TV has no AV input terminals, set the channel on the TV to correspond to the CH3-CH4 switch on the back of the VCR.
- Even if your TV has AV input terminals, you must connect it to the VCR using an RF cable in order to record one show while watching another (pg. 25).
- For full identification of the VCR's rear panel, refer to the Index (REAR VIEW pg. 43).

Plug & Play

Auto Tuner Set

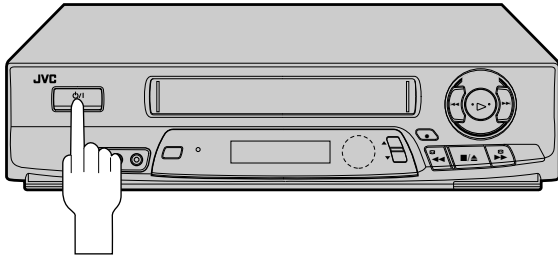

IMPORTANT

- Don't press any buttons on the VCR or remote while Plug & Play is in progress.
- If you perform Plug & Play successfully, there's no need to perform the Tuner procedures (pg. 8). If, however, you want to add or delete channels, refer to "Add Or Delete A Channel" on page 10.

The Plug & Play function sets the tuner channels automatically when the **POWER** button is first pressed to power on the VCR after you connect the power plug to an AC outlet.

1 PLUG & PLAY SETUP

Connect the antenna cable to the VCR (pg. 4). Then connect the VCR's power plug to an AC outlet.

1
2
3

2 TURN ON THE VCR

Press **POWER**. The tuner channels will automatically be set.

- The auto channel set function scans all the channels that are receivable by your VCR. It then automatically assigns each receivable channels to the **CH▲▼** buttons. It skips non-receivable channels. During auto channel set the channel numbers are displayed as they are scanned and set.
- After you perform Plug & Play, if the tuner channels have not been set properly or if "SIN SEÑAL" is displayed on screen, make sure that the antenna cable is connected to the VCR properly and turn off the VCR power once, then turn the power back on; the VCR will try Plug & Play again.

3 RETURN TO NORMAL SCREEN

Press **MENU** as many times as necessary.

On-Screen Display

AJUSTE AUTOMATICO DE CANALES

EXPLORANDO ...

PRESIONE (MENU) P/TERMINAR

During Plug & Play
The channel numbers are displayed as they are scanned and set.

CH 40

Front Display Panel

➔

AJUSTE AUTOMATICO DE CANALES

FIN DE EXPLORACION

PRESIONE (MENU) P/TERMINAR

When Plug & Play is completed, the lowest position number will appear on the front display panel.

CH 1

Be sure to connect the power plug to an AC outlet first before installing the lithium battery; otherwise, the battery's service life will be drastically shortened.

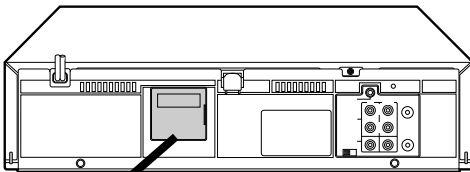

Installing/Removing the lithium battery

- 1 Make sure that the power plug is connected to an AC outlet and turn off the VCR power.
- 2 Open the battery cover while pressing the release tab as illustrated.
- 3 Insert a lithium battery with the plus (+) side up and push it in.
 - To remove the lithium battery, press the latch **A** downward using a pointed non-metallic object, then pull out the lithium battery.
- 4 Close the battery cover until it clicks in place.

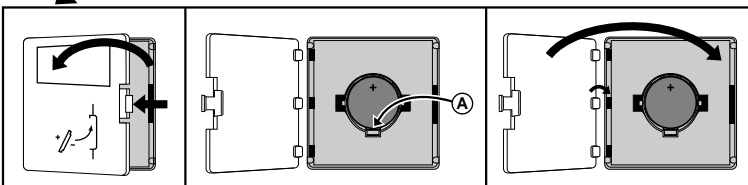

Clock

Turn on the TV and select the VCR channel 3 or 4 (or AV mode).

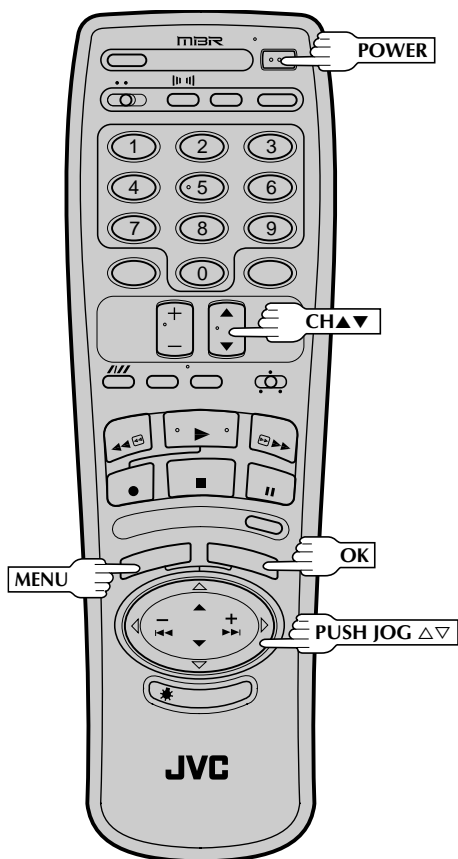
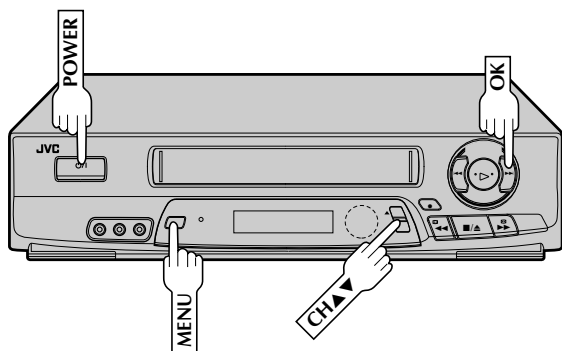

Preparation

1 TURN ON THE VCR

Press **POWER**.

2 ACCESS ON-SCREEN MENU

Press **MENU** to bring up the Main Menu screen.

3 ACCESS INITIAL SET SCREEN

At the Main Menu screen, place the arrow next to "AJUSTE INICIAL" by pressing **CH▲▼** or **PUSH JOG▲▼** then press **OK**.

MENU PRINCIPAL

→ AJUSTE DE PROGRAMA
AJUSTE DE FUNCION
AJUSTE DE SINTONIZADOR
AJUSTE INICIAL
IMAGEN B.E.S.T.
ESTABILIZADOR DE VIDEO
PRESIONE (▲,▼) LUEGO (OK)
PRESIONE (MENU) P/TERMINAR

Language Select

1 ACCESS LANGUAGE SELECT SCREEN

The messages are preset to appear in Spanish. If you want to see them in English, place the arrow next to "SELECCION DE IDIOMA" by pressing **CH▲▼** or **PUSH JOG▲▼**, then press **OK**.

AJUSTE INICIAL

AJUSTE DEL RELOJ
→ SELECCION DE IDIOMA
SUPER LIVE SURROUND
PRESIONE (▲,▼) LUEGO (OK)
PRESIONE (MENU) P/TERMINAR

2 SELECT LANGUAGE

At the Language Select screen, place the arrow next to the desired language by pressing **CH▲▼** or **PUSH JOG▲▼**, then press **MENU**. The Initial Set screen reappears.

LANGUAGE SELECT

→ ENGLISH
ESPAÑOL
PRESS (▲,▼) TO SELECT
PRESS (MENU) TO END

Clock Setting

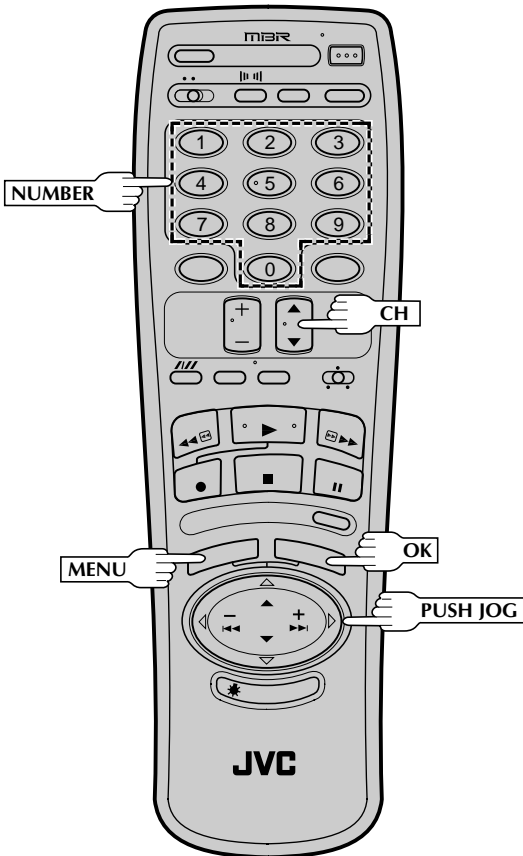
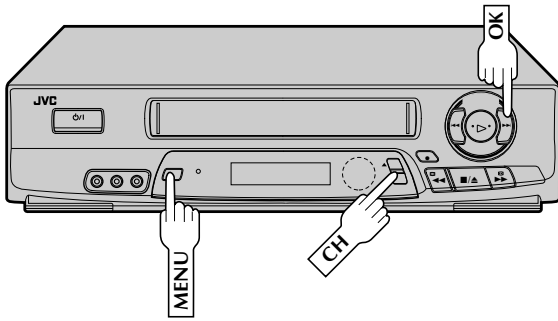

1 ACCESS CLOCK SET SCREEN

Place the arrow at the Initial Set screen next to "CLOCK SET" by pressing **CH▲▼** or **PUSH JOG▲▼**, then press **OK**.

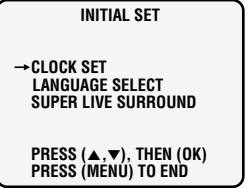

2 SET DATE AND TIME

Press the appropriate **NUMBER** keys to set the date and time (if only 1 digit, press "0" first). Press **CH▲▼** or **PUSH JOG▲▼** to set AM/PM, then press **OK**. The next setting that can be set begins flashing. When you're finished with this set-up procedure, press **MENU** to start the clock.

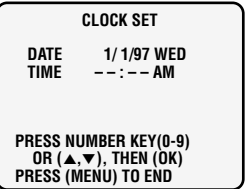

NOTE:

CH▲▼ and **PUSH JOG▲▼** can be used to perform all operations. (In this case, press **OK** after each setting.)

3 MAKE CORRECTIONS

To change any of the settings, press **OK** or **PUSH JOG** ◀▶ until the item you want to change blinks, then set as in step 2.

Tuner

Turn on the TV and select the VCR channel 3 or 4 (or AV mode).

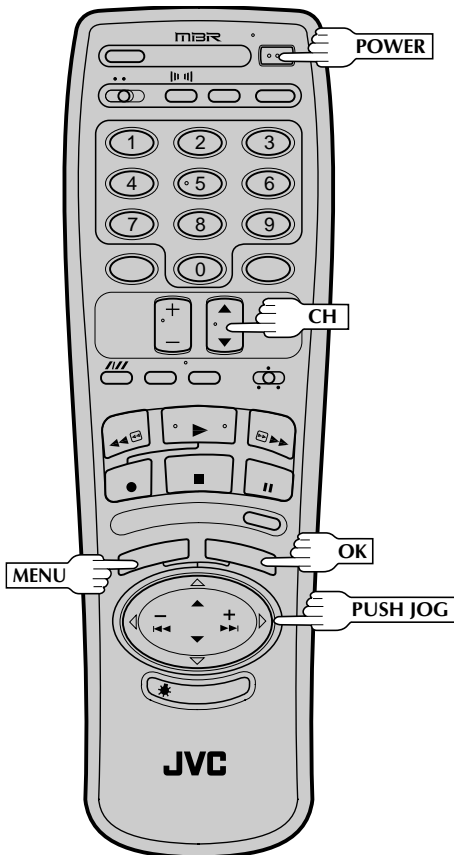
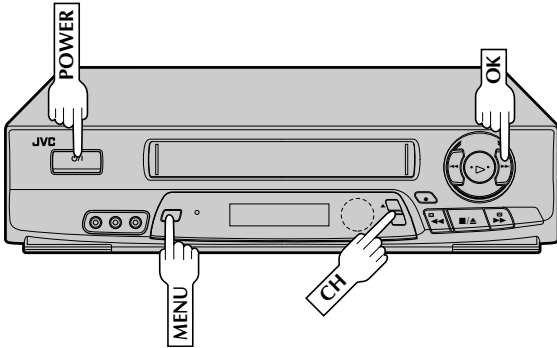

Set Receivable Channels

1 TURN ON THE VCR

Press **POWER**.

2 ACCESS MAIN MENU SCREEN

Press **MENU**.

3 ACCESS TUNER SET SCREEN

Place the arrow next to "TUNER SET" by pressing **CH▲▼** or **PUSH JOG▲▼**, then press **OK**.

4 ACCESS BAND SCREEN

Place the arrow next to "BAND" by pressing **CH▲▼** or **PUSH JOG▲▼**, then press **OK**.



5 SET FREQUENCY BAND

If you receive your TV channels from an external antenna, select "TV". If you receive your TV channels from a cable TV system, select "CATV". Place the arrow next to your choice by pressing **CH▲▼** or **PUSH JOG▲▼**, then press **MENU** to return to the Tuner Set screen.

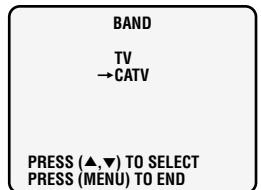

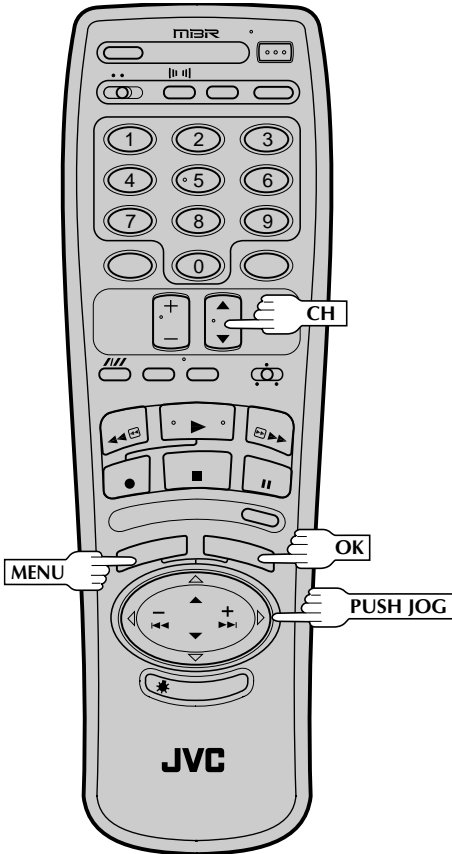
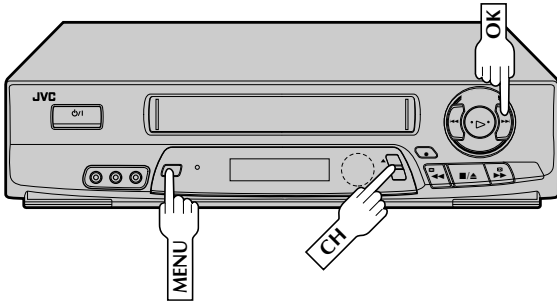

6

PERFORM AUTO CHANNEL SET

Place the arrow next to "AUTO CHANNEL SET" by pressing **CH▲▼** or **PUSH JOG▲▼**, then press **OK**.

Receiveable channels in your area are automatically assigned to the **CH▲▼** buttons, and non-receiveable channels are skipped.

AUTO CHANNEL SET

SCANNING ...

PRESS (MENU) TO END

NOTES:

- At the end of Auto Channel Set, "SCAN COMPLETED" appears on screen.
- If the scan was unsuccessful, "SCAN COMPLETED—NO SIGNAL—" appears on screen. Check the band setting and connections and start again.

RETURN TO NORMAL SCREEN

Press **MENU** as many times as necessary.

7

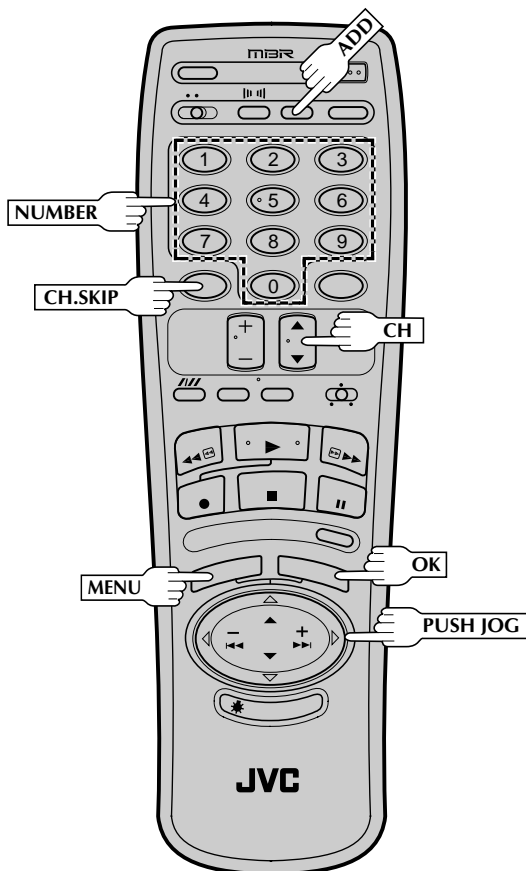
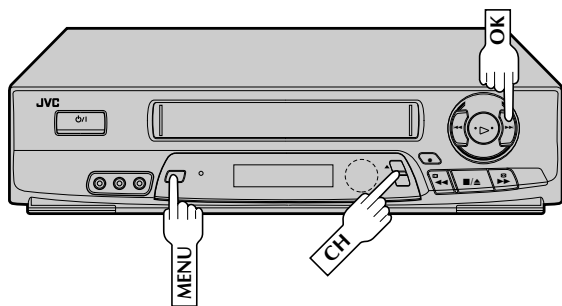

Add Or Delete A Channel

1

ACCESS TUNER SET SCREEN

Access by performing steps 2 and 3 of the Tuner procedure on page 8.

- To add a channel, go to step 2.
- To delete a channel, skip to step 4.

2

ACCESS AFC SCREEN

Place the arrow next to "AFC" by pressing CH▲▼ or PUSH JOG▲▼, then press OK.

3

MAKE SELECTION

Place the arrow next to "SPCL" by pressing CH▲▼ or PUSH JOG▲▼, then press MENU to return to the Tuner Set screen.

- It is necessary to set AFC to SPCL (special) for tuning on certain CATV systems.

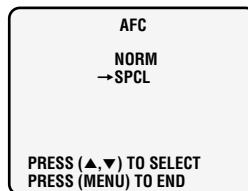

4

ACCESS MANUAL CHANNEL SET SCREEN

Place the arrow next to "MANUAL CHANNEL SET" by pressing CH▲▼ or PUSH JOG▲▼, then press OK.

5

STORE DESIRED CHANNEL

Input the channel number using the NUMBER keys or by pressing CH▲▼ or PUSH JOG▲▼, then press ADD to add or CH.SKIP to delete. Repeat for each channel you want to store or skip.

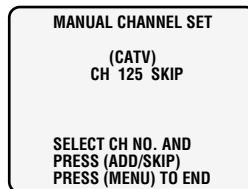

6

RETURN TO NORMAL SCREEN

Press MENU as many times as necessary.

Simple Playback

Turn on the TV and select the VCR channel 3 or 4 (or AV mode).

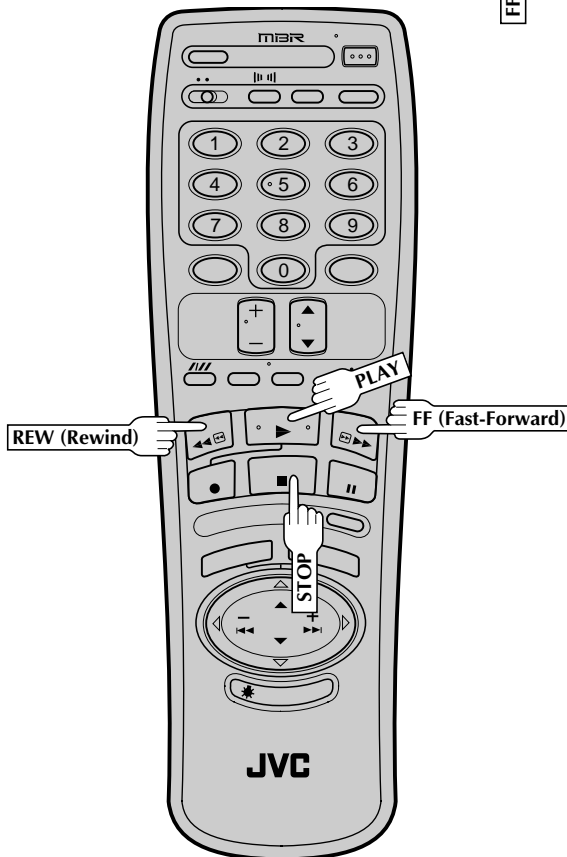
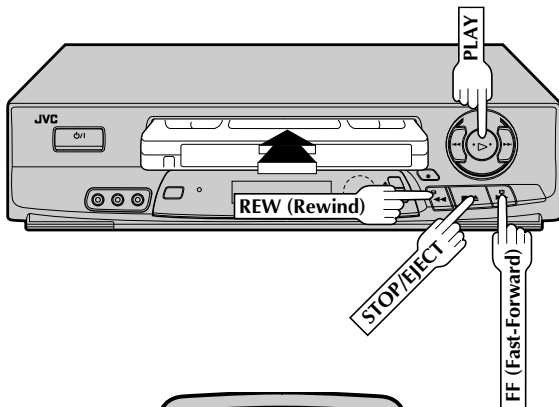

1 LOAD A CASSETTE

Make sure the window side is up, the rear label side is facing you and the arrow on the front of the cassette is pointing towards the VCR. Don't apply too much pressure when inserting.

- The VCR's power comes on automatically.
- The counter is automatically reset to "0H 00M 00S".
- If the cassette's record safety tab has been removed, playback begins automatically.

2 FIND PROGRAM START POINT

If the tape is advanced past the start point, press **REW**. To go forward, press **FF**.

3 START PLAYBACK

Press **PLAY**. "B.E.S.T. PICTURE SYSTEM" appears on screen (pg. 24).

4 STOP PLAYBACK

Press **STOP** or **STOP/EJECT**. Then press **STOP/EJECT** to remove the cassette.

Usable cassettes

Full-Size VHS
 T-30 (ST-30**)
 T-60 (ST-60**)
 T-90
 T-120 (ST-120**)
 T-160 (ST-160**)
 ST-210**

Compact VHS*
 TC-20 (ST-C20**)
 TC-30 (ST-C30**)
 TC-40 (ST-C40**)

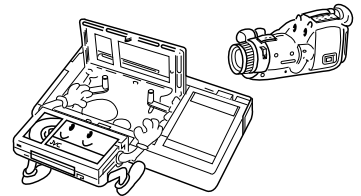

* Compact VHS camcorder recordings can be played on this video recorder. Simply place the recorded cassette into a VHS Cassette Adapter and it can be used just like any full-sized VHS cassette.

** This video recorder can record on regular VHS and Super VHS cassettes. However, it will record and play back regular VHS signals only. It is not possible to play back Super VHS recordings.

Simple Recording

Turn on the TV and select the VCR channel 3 or 4 (or AV mode).

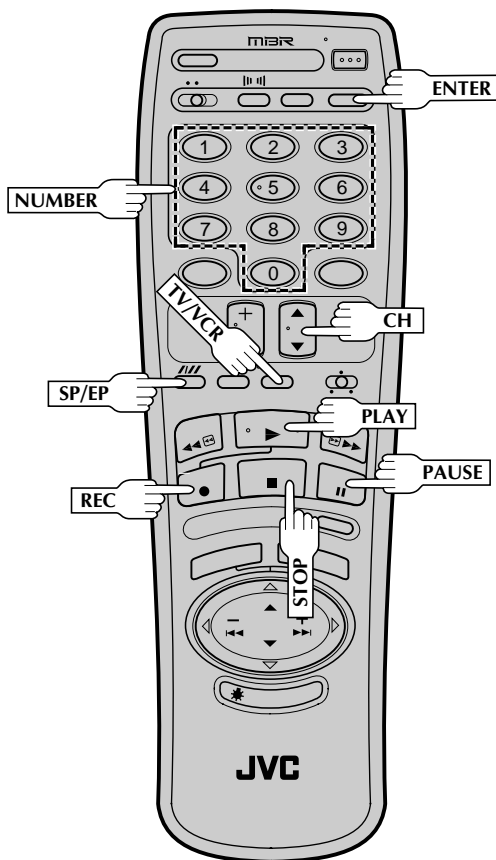
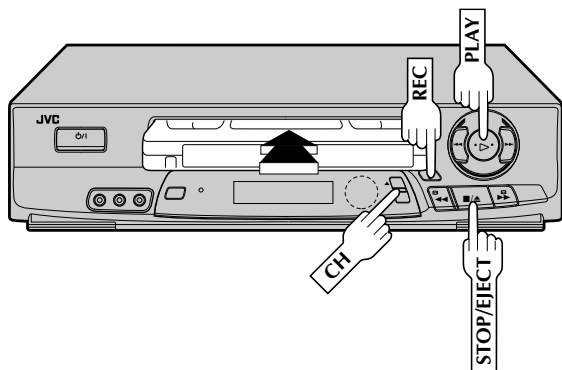

1 LOAD A CASSETTE

Make sure the record safety tab is intact. If not, cover the hole with adhesive tape before inserting the cassette.

2 SELECT RECORDING CHANNEL

Press **CH▲▼**. Or press the appropriate **NUMBER** keys, then press **ENTER**. (The channel changes after a few seconds whether you press **ENTER** or not.)

- If you use the RF connection, by pressing the **TV/VCR** button, select VCR mode to view the program to be recorded.

3 SET TAPE SPEED

Press **SP/EP** to set the recording speed.

4 START RECORDING

Press and hold **REC** and press **PLAY** on the remote control, or press **REC** on the VCR's front panel.

B.E.S.T. takes place at the beginning of both the first SP and the first EP recording after inserting the cassette (see pg. 23).

5 PAUSE/RESUME RECORDING

Press **PAUSE**. Press **PLAY** to resume recording.

- During record pause, you can change the recording channel by using the **CH▲▼** buttons or **NUMBER** keys.

6 STOP RECORDING

Press **STOP** or **STOP/EJECT**. Then press **STOP/EJECT** to remove the cassette.

Recording Resume Function

If there is a power outage during recording (or Instant Timer Recording or timer recording), the recording will resume automatically when power is restored to the VCR.

Accidental erasure prevention

- To prevent accidental recording on a recorded cassette, remove its record safety tab. To record on it later, cover the hole with adhesive tape.

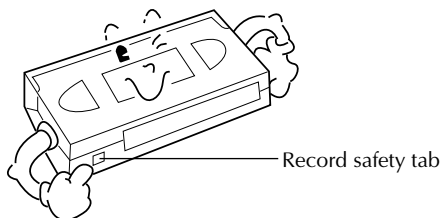

Playback Features

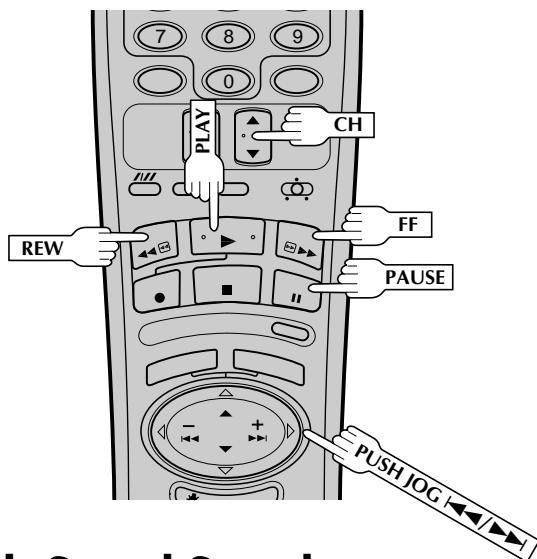
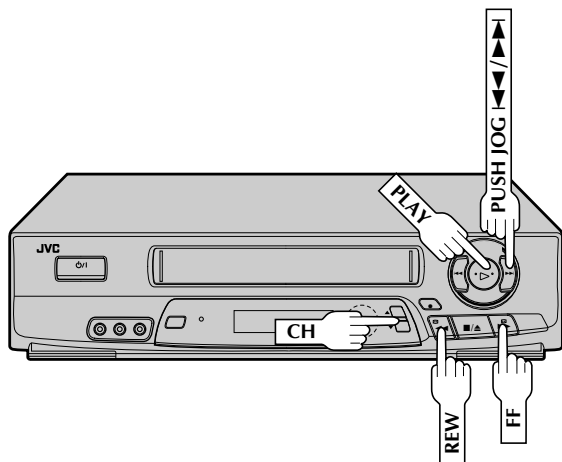

High-Speed Search

1 ACTIVATE HIGH-SPEED SEARCH

During playback or still press **FF** for forward high-speed search, or **REW** for reverse high-speed search.

To resume normal playback, press **PLAY**.

NOTE:

For short searches, during playback or still press and hold **FF** or **REW** for over 2 seconds. When released, normal playback resumes.

Still Picture/Frame-By-Frame Playback

1 PAUSE DURING PLAYBACK

Press **PAUSE**. If there is vertical jitter, use the **CH** ▲ or ▼ button to correct the picture.

2 ACTIVATE FRAME-BY-FRAME PLAYBACK

Press **PAUSE** repeatedly to advance one frame at a time.

Press **PUSH JOG** ◀◀ or ▶▶ repeatedly to advance one frame at a time.

Press **PUSH JOG** ▶▶ for forward frame by frame playback or **PUSH JOG** ◀◀ for reverse frame by frame.

To resume normal playback, press **PLAY**.

Slow Motion/Reverse Slow Motion

1 ACTIVATE SLOW-MOTION PLAYBACK

During still picture, press and hold **PUSH JOG** ◀◀ or ▶▶. Release to return to still picture.

OR
For hands-free slow-motion, press **PUSH JOG** ◀◀ during playback to decrease speed in the forward direction. Continue to press ◀◀ to select the various slow motion, reverse slow motion, reverse play and reverse search modes.

To resume normal playback, press **PLAY**.

NOTE:

If noise bars appear during slow motion, press **CH** ▲ or ▼ a few times to remove the noise bars from screen.

Variable-Speed Search/Reverse Motion Playback

1 ACTIVATE VARIABLE-SPEED SEARCH

During playback, press **PUSH JOG** ◀◀ or ▶▶.

- To increase the speed in the forward direction, press ▶▶ repeatedly to select the various forward search modes.
- To decrease the speed in the forward direction, press ◀◀.
- To play in reverse slow motion, and in reverse play mode, continue to press ◀◀ after selecting all the forward slow motion modes.

To resume normal playback, press **PLAY**.

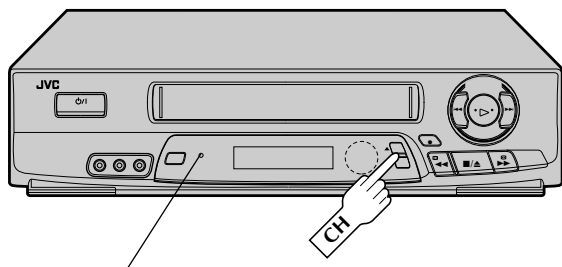

SUPER LIVE SURROUND indicator

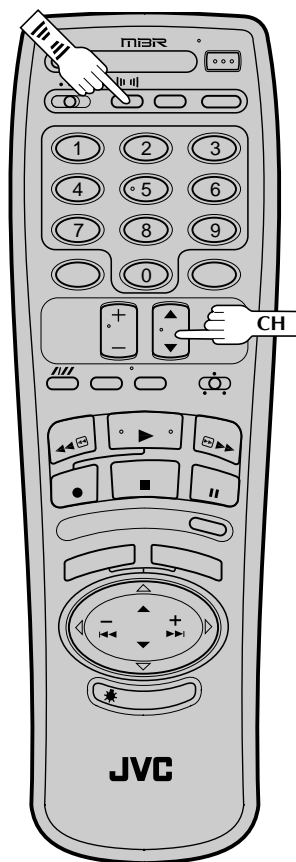

Manual Tracking

Once playback begins, the VCR's automatic tracking function is engaged. If noise appears in the picture, you can override this and make the adjustment manually.

1 ENGAGE MANUAL TRACKING MODE

During playback, press the **CH▲▼** buttons on the VCR's front panel simultaneously to cancel the automatic tracking mode and enable manual tracking adjust.

2 ADJUST MANUAL TRACKING

Press **CH▲▼** on the VCR's front panel or remote. Press lightly for fine adjust, or press and hold for coarse adjust. Watch the screen and continue adjusting until optimum picture and sound quality are achieved.

3 RE-ENGAGE AUTOMATIC TRACKING

Press the **CH▲▼** buttons on the VCR's front panel simultaneously.

- When automatic tracking is re-engaged, B.E.S.T. is automatically activated.

NOTES:

- To obtain a noiseless still picture it may be necessary to adjust tracking in slow playback and then engage Pause.
- Manual tracking is possible during hands-free slow-motion. During hands-free slow-motion playback, simply press **CH▲** or **▼** on the VCR's front panel or remote to adjust tracking.

Super Live Surround

To enjoy more dynamic stereo sound with Hi-Fi stereo tapes.

1 ACTIVATE SUPER LIVE SURROUND

Press **|||** during playback or stop.

- Pressing the **|||** button turns on/off the SUPER LIVE SURROUND indicator on the VCR.

NOTE:

You can also change the setting at the on-screen menu:

1. Press **MENU**.
2. Place the arrow next to "INITIAL SET" by pressing **CH▲▼**, then press **OK**.
3. Place the arrow next to "SUPER LIVE SURROUND" by pressing **CH▲▼**, then press **OK**.
4. Place the arrow next to "ON" or "OFF" by pressing **CH▲▼**, then press **MENU** as many times as necessary.

Video Stabilizer

You can correct vertical vibration when playing back unstable EP recordings that were made on another VCR. When this function is set to "ON", vertical vibration will be automatically corrected. *The default setting is "OFF".

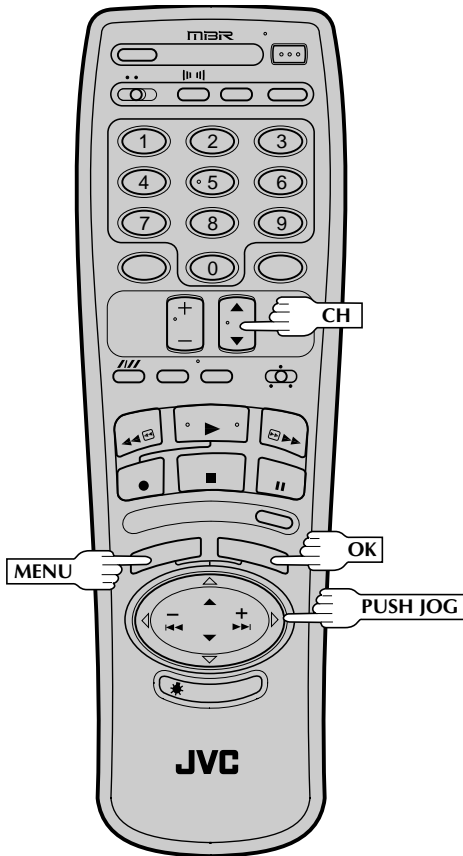
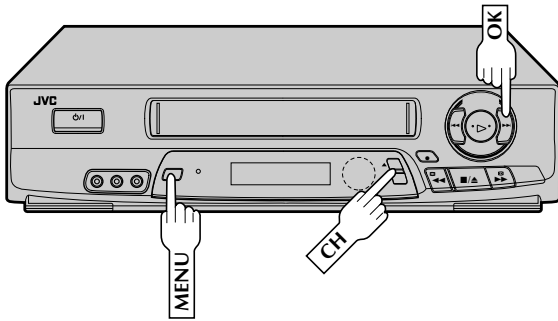

1 ACCESS MAIN MENU SCREEN

Press MENU.

2 ACCESS VIDEO STABILIZER SCREEN

Place the arrow next to "VIDEO STABILIZER" by pressing CH▲▼ or PUSH JOG ▲▼, then press OK.



3 ACTIVATE VIDEO STABILIZER

Place the arrow next to "ON" by pressing CH▲▼ or PUSH JOG ▲▼.

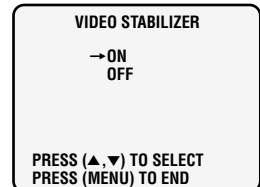

4 RETURN TO NORMAL SCREEN

Press MENU.

NOTES:

- Regardless of the setting, this function has no effect with SP recordings, during recording and during special-effects playback.
- When you finish viewing the tape, be sure to set it back to "OFF".

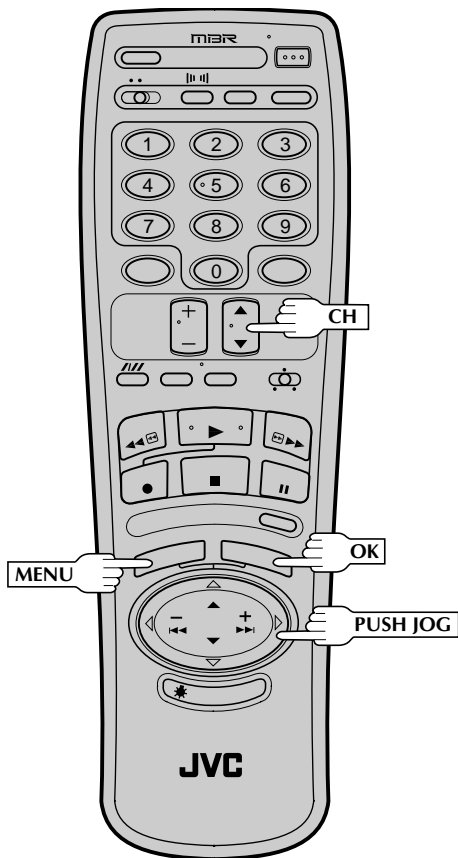
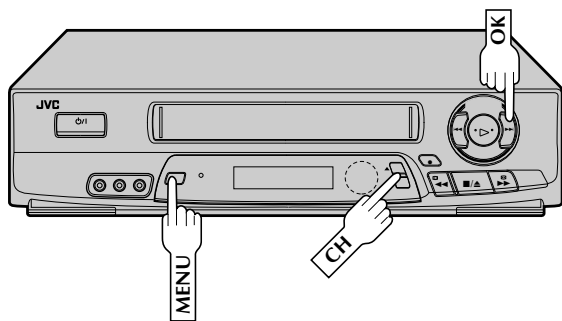

Select The Soundtrack

Your VCR can record two soundtracks simultaneously (Normal and Hi-Fi) and play back the selected one, or both together. Or, when viewing a pre-recorded tape that contains both a main and a sub audio track, you can choose to listen to either one by selecting either "L" or "R" in step 4.

1 ACCESS MAIN MENU SCREEN

Press **MENU** during playback or when VCR is in stop mode.

2 ACCESS FUNCTION SET SCREEN

Place the arrow next to "FUNCTION SET" by pressing **CH▲▼** or **PUSH JOG▲▼**, then press **OK**.

3 ACCESS AUDIO MONITOR SCREEN

Place the arrow next to "AUDIO MONITOR" by pressing **CH▲▼** or **PUSH JOG▲▼**, then press **OK**.

FUNCTION
AUTO TIMER
SUPERIMPOSE
2ND AUDIO
→AUDIO MONITOR
AUX INPUT
AUTO SP/EP TIMER
SPECIAL FUNCTION
PRESS (▲, ▼), THEN (OK)
PRESS (MENU) TO END

4 SELECT MODE

You have five choices:

- a- Hi-Fi
- b- Left
- c- Right
- d- Normal
- e- Mix

AUDIO MONITOR
→HI-FI
L
R
NORM
MIX
PRESS (▲, ▼) TO SELECT
PRESS (MENU) TO END

Place the arrow next to your choice by pressing **CH▲▼** or **PUSH JOG▲▼**.

- The indicator on the front display panel representing the mode you selected lights up (Hi-Fi: L+R; L: L; R:R; NORM: NORM; MIX: L+R).

5 RETURN TO NORMAL SCREEN

Press **MENU** as many times as necessary.

NOTE:

If the tape being played back has no Hi-Fi soundtrack, the Normal soundtrack will be heard no matter what choice you make at the Audio Monitor screen.

Superimpose

This function, switchable between ON and OFF, determines whether or not operational indicators will appear on screen.

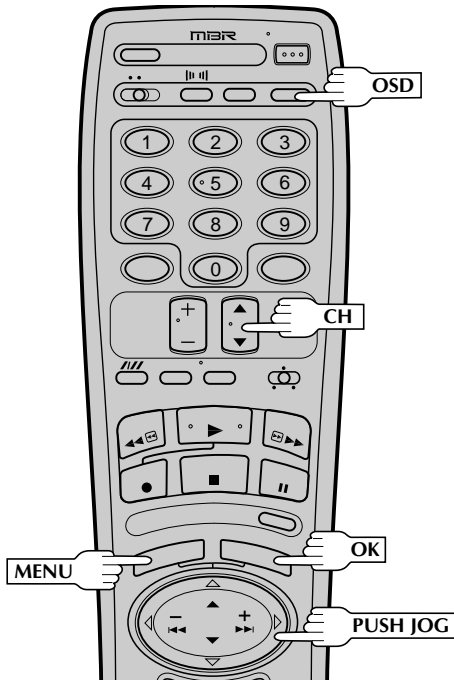
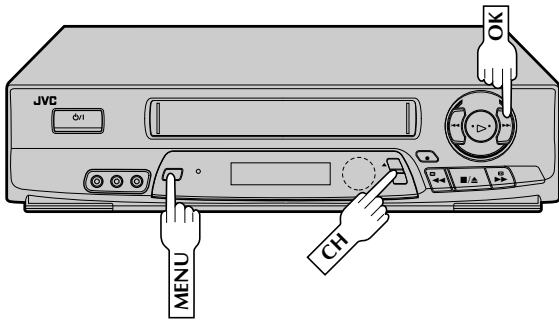

To recall an indication

- 1 Press **OSD**.
 - All indications corresponding to the current status are displayed for 5 seconds, leaving the counter information, and RECORD/PAUSE if in the Record Pause mode, on the screen. (No indication during still and search.)
- 2 Press **OSD** again to clear the display.

The superimposed indication on the TV screen tells you what the VCR is doing.

- Tuned-in channel or AUX(iliary) mode**
When the channel is changed, the new channel is displayed on the screen for 5 seconds.
- Clock time**
- Tape position indicator**
- "Cassette Loaded" mark**
When a cassette is loaded, the mark is displayed for 5 seconds. It blinks when the VCR's EJECT button is pushed.

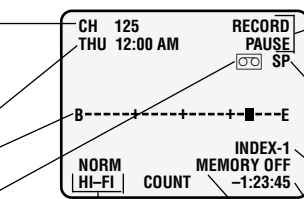

Audio mode indicators

Counter memory on/off

Operation mode

When the operation mode is changed, the new mode is displayed — RECORD (5 sec.), PLAY (5 sec.), FF/REW (5 sec.) when engaged from Stop mode), RECORD PAUSE (for as long as Pause is engaged), and ITR **:*(5 sec.).

Tape speed indicator

INDEX indication

Counter reading

1 ACCESS MAIN MENU SCREEN

Press **MENU**.

2 ACCESS FUNCTION SET SCREEN

Place the arrow next to "FUNCTION SET" by pressing **CH▲▼** or **PUSH JOG△▽**, then press **OK**.

3 ACCESS SUPERIMPOSE SCREEN

Place the arrow next to "SUPERIMPOSE" by pressing **CH▲▼** or **PUSH JOG△▽**, then press **OK**.

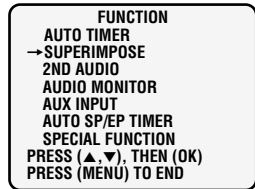

4 SELECT MODE

Place the arrow next to "ON" or "OFF" by pressing **CH▲▼** or **PUSH JOG△▽**.

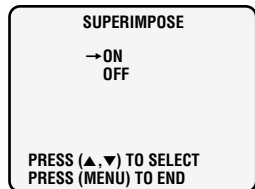

5 RETURN TO NORMAL SCREEN

Press **MENU** as many times as necessary.

NOTE:

If you engage the Record Pause mode, RECORD/PAUSE is displayed whether "SUPERIMPOSE" is set to "ON" or "OFF".

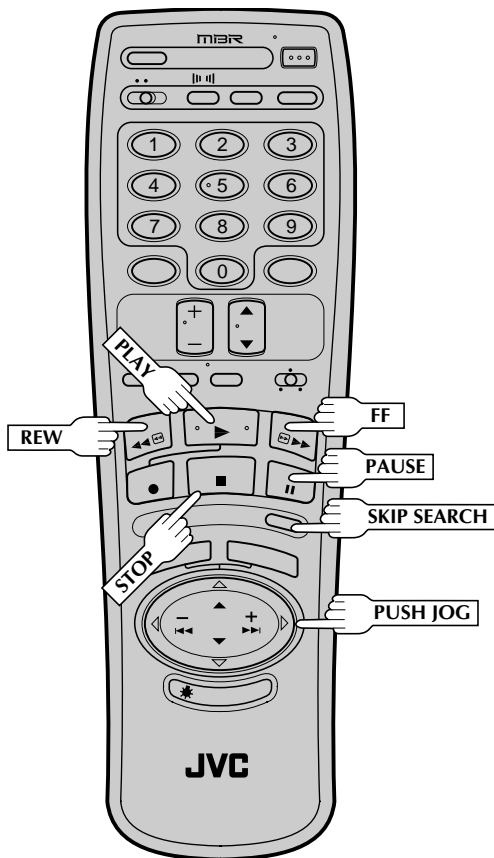
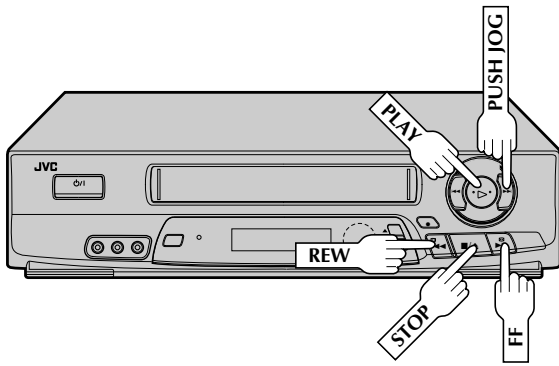

Skip Search

1 SKIP OVER UNWANTED SECTIONS

Press **SKIP SEARCH** 1 to 4 times during playback. Each press initiates a 30-second period of fast-motion playback. Normal playback resumes automatically.

NOTE:

To return to normal playback during a Skip Search, press **PLAY**.

Repeat Playback

1 START REPEAT

Press and hold **PLAY** (until "PLAY" blinks on the front display panel) during playback, then release.

- The entire tape is played back 20 times.

2 STOP REPEAT

To stop, press **STOP** at any time.

NOTE:

Pressing **PLAY**, **REW**, **FF**, **PAUSE** or **PUSH JOG** ◀◀ or ▶▶ also stops Repeat Playback.

Index Search

Index codes are placed on the tape at the start of each recording. You can find and automatically play back from the start of any recording using the Index Search function.

1 START SEARCH

While the tape is stopped, press **PUSH JOG** ◀◀ or ▶▶.

2 ACCESS DISTANT CODE

To access a recording 2–9 index codes away, press **PUSH JOG** ◀◀ or ▶▶ repeatedly until the correct number is displayed on screen (only if **SUPERIMPOSE** is set to **ON** (pg. 17)). Playback begins automatically when desired recording is located.

- If necessary press **REW** or **FF** when play starts to search visually to find the very beginning of the desired program.

NOTE:

An index code is not placed on the tape when recording is paused and then resumed.

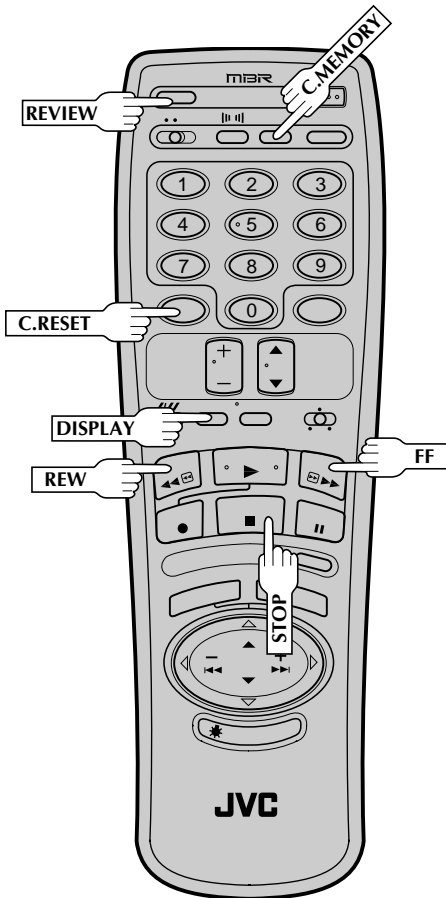
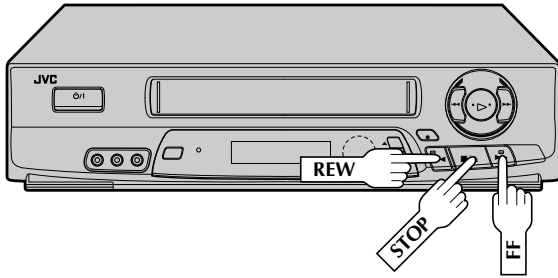

Instant ReView

At the press of a button, you can power up your VCR, rewind the tape and begin viewing the most recent timer-recorded program.

1

ACTIVATE INSTANT REVIEW

After ensuring that the Timer mode is disengaged, press **REVIEW**.

- The power comes on and the VCR searches for the index code indicating the start of the last timer-recorded program, then begins playback automatically.
- You can access a program 2–9 index codes away from the current position on the tape. If, for example, you have 5 programs recorded and you want to watch the third one, press **REVIEW** three times.
- If necessary press **REW** or **FF** when play starts to search visually to find the very beginning of the desired program.
- If the tape is already rewound when **REVIEW** is pressed, it will play the tape from the beginning. It will not fast forward to an index code.
- The Instant Review function will also operate if the VCR's power is on.

Counter Reset

1

RESET COUNTER TO ZERO

Press **C.RESET**.

NOTE:

By pressing the **DISPLAY** button, you can change the display to show the counter reading, channel number or clock time. (Channel number is not displayed during playback.)

Counter Memory

When activated, this feature returns the tape to counter position "zero".

1

ACTIVATE COUNTER MEMORY

Press **C.RESET** during playback at a point you want to have quick access to later. The counter reads "0H 00M 00S".

Then press **C.MEMORY**. The Counter Memory indicator in the front display panel lights.

RETURN TO COUNTER POSITION ZERO

2

Press **STOP** (during playback), then press **REW** or **FF**. The tape rewinds or fast-forwards and stops at approximately "0H 00M 00S" automatically.

- To cancel Counter Memory, press **C.MEMORY**.

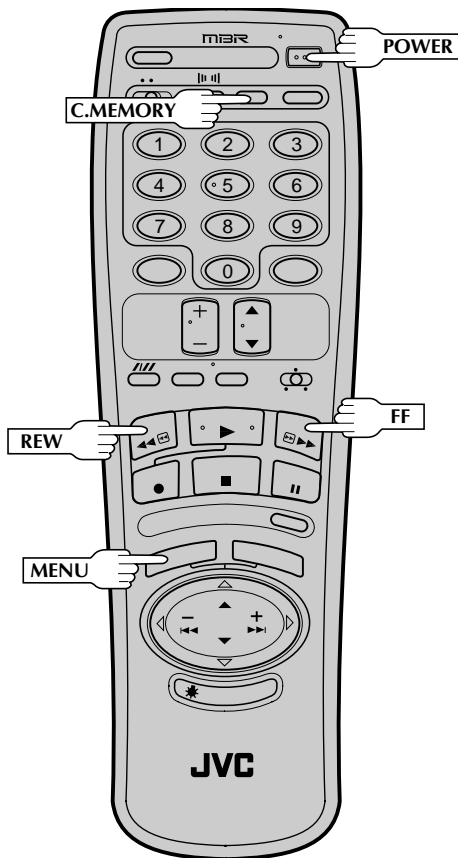
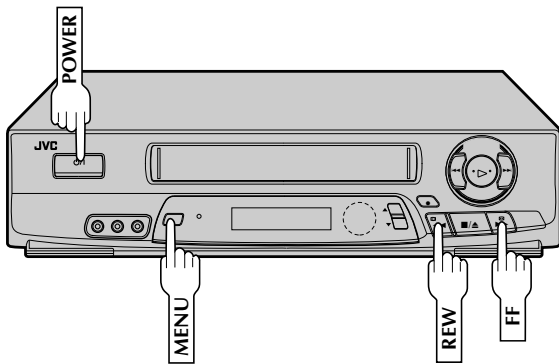

Tape Position Indicator

The Tape position indicator appears on screen when, from the stop mode, you press **FF**, **REW** or perform an Index Search or Instant ReView. The position of "■" in relation to "B" (Beginning) or "E" (End) shows you where you are on the tape.

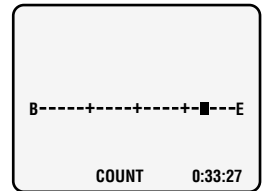

NOTE:

SUPERIMPOSE must be set to ON, or the indicator will not appear (see pg. 17).

Next Function Memory

You can set your VCR's power to go off automatically after the tape is fully rewound. Before starting, make sure the VCR is in the Stop mode.

For Automatic Power Off After Tape Rewind . . .
 . . . press **REW**, then press **POWER** within 2 seconds.

NOTE:

*If you want the power to be turned off automatically when the counter reads "0H00M00s" (instead of at the beginning of the tape), press **C.MEMORY** so that the "M" mark appears before pressing **REW**.*

AV COMPU LINK Playback

Your VCR is compatible with JVC's AV COMPU LINK components, including amplifiers (or receivers) and televisions. AV COMPU LINK provides one touch control of the audio and video components that are linked via their AV COMPU LINK connectors.

For example: simply load a cassette in the VCR and press **PLAY** and the AV COMPU LINK components automatically power on, the TV's VIDEO mode is selected and the VCR goes into play mode. (**PLAY** need not be pressed if the cassette's record safety tab is removed.)

1 MAKE CONNECTION

Connect your VCR to an AV COMPU LINK component as shown in the illustration on page 21.

- The Mini-plug cable is a mono 3.5 mm mini-plug to mono 3.5 mm mini-plug connector.

2 TURN ON THE VCR

Press **POWER**.

3 ACCESS MAIN MENU SCREEN

Press **MENU**.

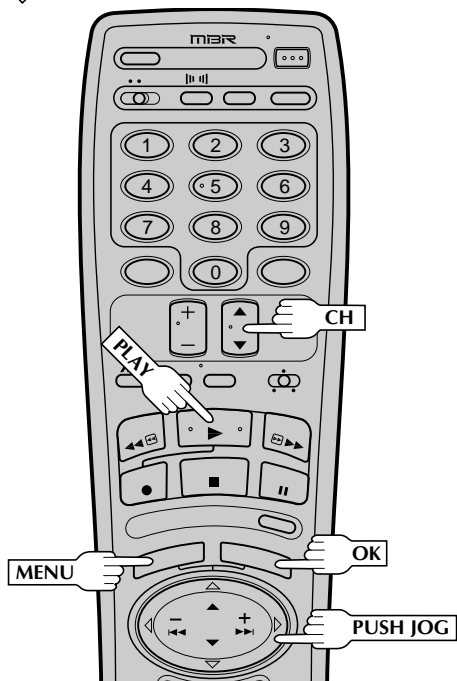
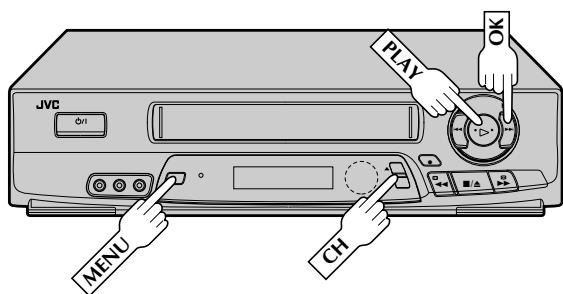

Example

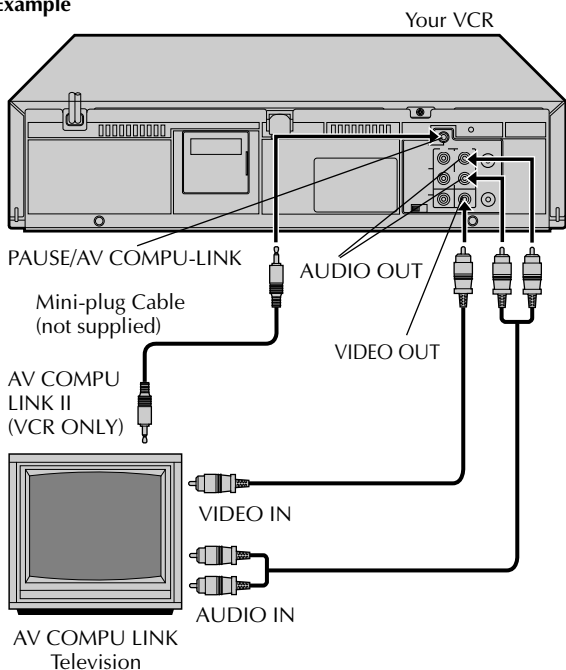

4

ACCESS FUNCTION SET SCREEN

Press **CH▲▼** or **PUSH JOG▲▼** to place the arrow next to "FUNCTION SET", then press **OK**.

5

ACCESS SPECIAL FUNCTION SCREEN

Press **CH▲▼** or **PUSH JOG▲▼** to place the arrow next to "SPECIAL FUNCTION", then press **OK**.

- | FUNCTION | |
|-------------------------|--|
| AUTO TIMER | |
| SUPERIMPOSE | |
| 2ND AUDIO | |
| AUDIO MONITOR | |
| AUX INPUT | |
| AUTO SP/EP TIMER | |
| →SPECIAL FUNCTION | |
| PRESS (▲, ▼), THEN (OK) | |
| PRESS (MENU) TO END | |

6

ENABLE AV COMPU LINK PLAYBACK

Press **CH▲▼** or **PUSH JOG▲▼** to place the arrow next to "AV COMPU-LINK".

- | SPECIAL FUNCTION | |
|------------------------|--|
| PAUSE | |
| →AV COMPU-LINK | |
| PRESS (▲, ▼) TO SELECT | |
| PRESS (MENU) TO END | |

7

RETURN TO NORMAL SCREEN

Press **MENU** as many times as necessary.

8

PERFORM AV COMPU LINK PLAYBACK

Simply insert a cassette and press **PLAY** (if the cassette's record safety tab has been removed, playback begins automatically). Linked components are turned on, and the TV set to its VIDEO mode, automatically!

NOTE:

Connection varies depending on the type of JVC TV you have. Please refer to the TV's instruction manual when making this connection.

B.E.S.T. Picture System

Turn on the TV and select the VCR channel 3 or 4 (or AV mode).

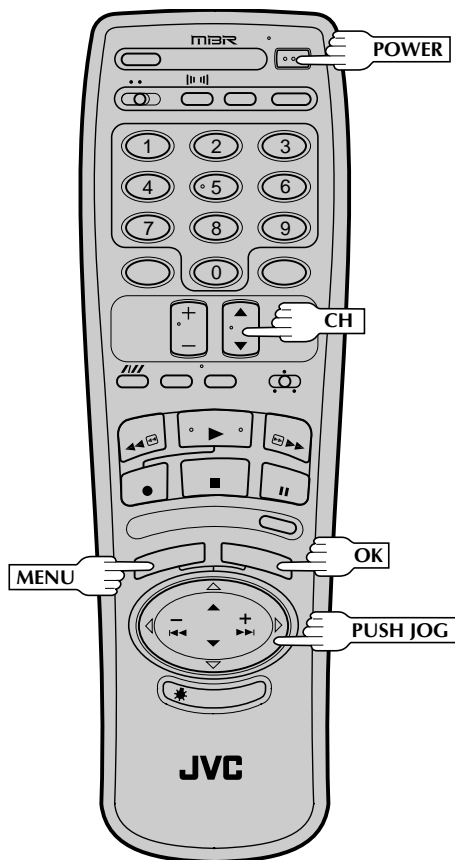
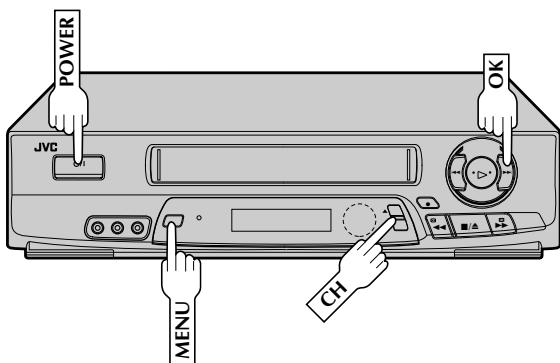

Your VCR is equipped with the B.E.S.T. (Biconditional Equalized Signal Tracking) feature, which checks the condition of the tape in use during recording and playback, and compensates to provide the highest-possible recording and playback pictures. *The default setting for both recording and playback is "ON".

Preparation

1 TURN ON THE VCR

Press **POWER**.

2 ACCESS MAIN MENU SCREEN

Press **MENU**.

3 ACCESS B.E.S.T. PICTURE SYSTEM SCREEN

Press **CH▲▼** or **PUSH JOG▲▼** to place the arrow next to "B.E.S.T. PICTURE SYSTEM", then press **OK**.



4 SELECT MODE

Place the arrow next to "ON" by pressing **CH▲▼** or **PUSH JOG▲▼**, then press **OK** to move the arrow to the Playback section. Set Playback to "ON", then press **MENU** to return to the normal screen. (Pressing **OK** returns the arrow to the Recording section.)

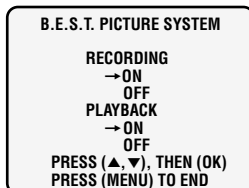

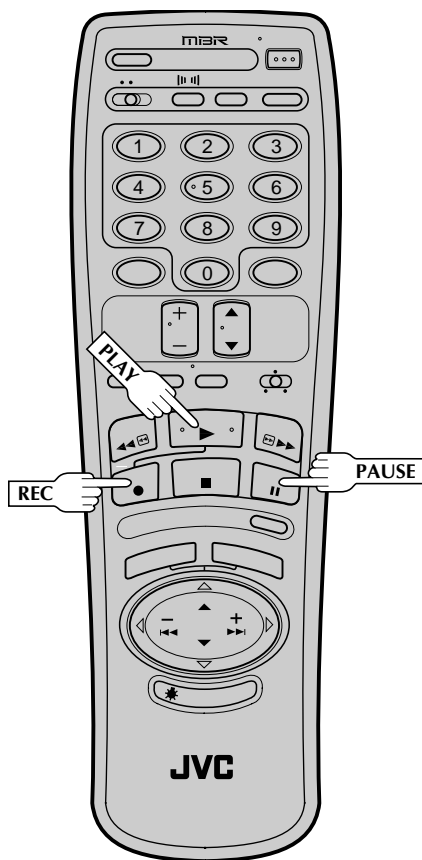
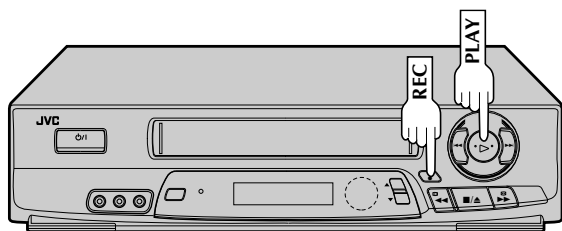

Recording

Perform steps 1 – 3 on page 12 ("Simple Recording") before continuing.

1

START RECORDING

Press and hold **REC** and press **PLAY** on the remote control, or press **REC** on the VCR's front panel.

- The VCR takes about 7 seconds to assess the quality of the tape in use, then recording begins with the picture level optimized.

NOTES:

- *B.E.S.T. occurs immediately prior to both the first SP and the first EP recording after inserting the cassette. It does not take place during recording.*
- *In the case of timer recording, B.E.S.T. takes place for both SP and EP before the first timer recording after inserting the cassette (regardless of the tape speed selected for that recording).*
- *Once the cassette is ejected, the B.E.S.T. data is canceled. The next time the cassette is used for recording, B.E.S.T. is re-performed.*
- *While B.E.S.T. is operative, the PAUSE button will not function.*
- *SUPERIMPOSE must be set to "ON" or the B.E.S.T. Picture System screen will not appear (pg. 17).*

DURING B.E.S.T.

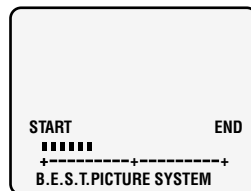

B.E.S.T. COMPLETE

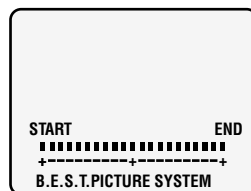

ATTENTION:

- As B.E.S.T. takes place before recording actually starts, there is a delay of about 7 seconds after **REC** and **PLAY** on the remote, or **REC** on the VCR's front panel, are pressed. To make sure you record the desired scene or program completely, first perform the following steps:
 - 1) Press and hold **PAUSE**, and press **REC** to engage the RECORD PAUSE mode.
 - The VCR then automatically checks the condition of the tape and, after about 7 seconds, re-enters RECORD PAUSE.
 - 2) Press **PLAY** to start recording.
- If you want to bypass B.E.S.T. and start recording right away, set "RECORDING" to "OFF" in step 4 of the Preparation procedure (pg. 22).

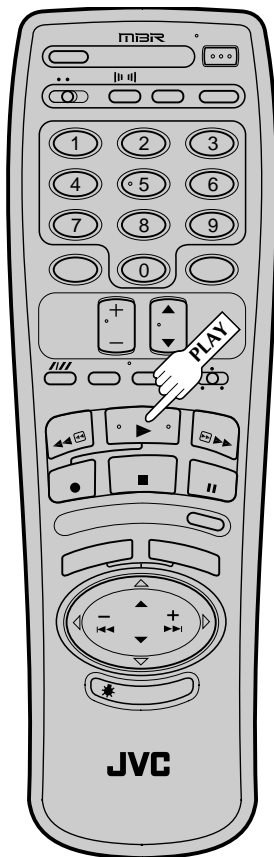
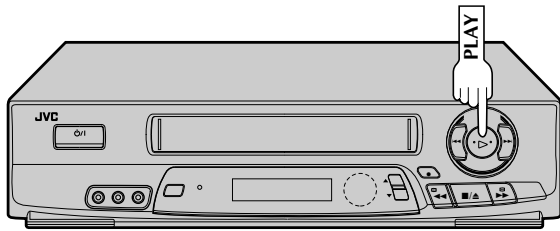

Playback

The VCR assesses the quality of the tape once you initiate playback.

Before beginning, perform steps 1 and 2 on page 11 ("Simple playback").

START PLAYBACK

Press **PLAY**.

- The VCR adjusts the playback picture quality based on the quality of the tape in use.



NOTES:

- When using rental tapes, or tapes recorded on other VCRs, set "PLAYBACK" in step 4 of the Preparation procedure to either "ON" or "OFF" as desired (☞ pg. 22).
- The B.E.S.T. Picture System screen only appears at the beginning of automatic tracking. Even though the screen doesn't appear after that, the B.E.S.T. function is operative.
- SUPERIMPOSE must be set to "ON" or the B.E.S.T. Picture System will not appear (☞ pg. 17).

Recording Features

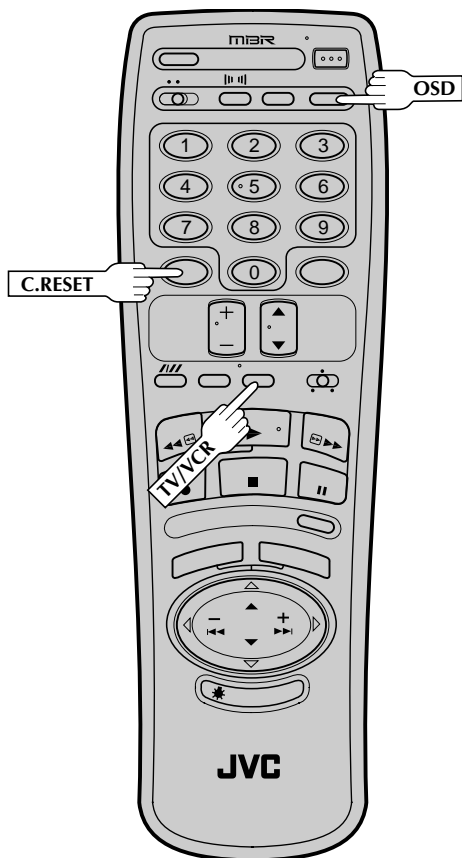
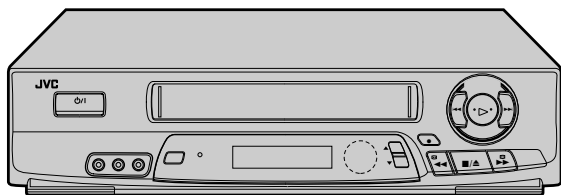

Record One Program While Watching Another

1 ENGAGE TV MODE

During recording...

- If using the RF connection (☞ pg. 4), press **TV/VCR**. The VCR's VCR indicator goes out and the TV broadcast being recorded disappears.
- If using the AV connection (☞ pg. 4), change the TV's input mode from AV to TV.

2 SELECT CHANNEL FOR VIEWING

Use the TV's channel selector to set the channel you want to watch.

Display Elapsed Recording Time

1 RESET COUNTER TO ZERO

Before recording starts, press **C.RESET**. The counter resets to zero and displays the exact elapsed time as the tape runs.

2 DISPLAY ELAPSED TIME ON SCREEN

During recording, press **OSD** at any time to see the elapsed time. All indications corresponding to the current status of the VCR are displayed for 5 seconds. The counter display remains on the screen indicating the elapsed time. Press **OSD** again to remove the display.

- Make sure "SUPERIMPOSE" is set to "ON" (☞ pg. 17).
- The indications are not be recorded.

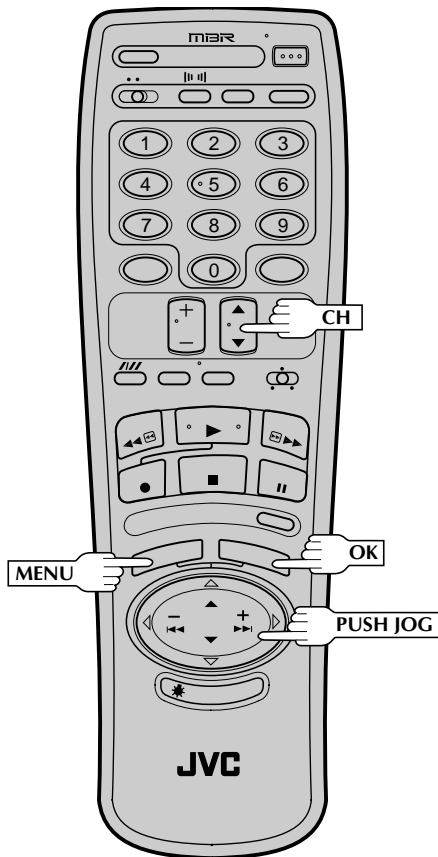
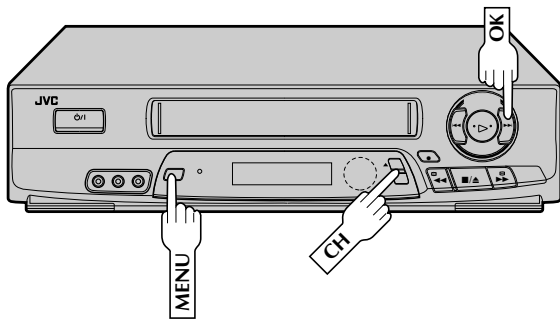

Stereo And SAP (Second Audio Program)

Your VCR's built-in MTS decoder enables reception of Multi-channel TV Sound broadcasts.

- The ST indicator on the front display panel lights during stereo broadcast reception, and SAP lights during SAP program reception.
- Both indicators light when a stereo program is accompanied by SAP audio.

To Record Stereo Programs . . .

. . . simply follow the basic recording procedure.

To Listen To Stereo Soundtrack During Recording . . .

. . . select "HI-FI" at the Audio Monitor screen (pg. 16).

To Record SAP Programs . . .

1 ACCESS MAIN MENU SCREEN

Press **MENU**.

2 ACCESS FUNCTION SET SCREEN

Place the arrow next to "FUNCTION SET" by pressing **CH▲▼** or **PUSH JOG▲▼**, then press **OK**.

3 ACCESS 2ND AUDIO SCREEN

Place the arrow next to "2ND AUDIO" by pressing **CH▲▼** or **PUSH JOG▲▼**, then press **OK**.

4 SELECT MODE

Place the arrow next to "ON" by pressing **CH▲▼** or **PUSH JOG▲▼**.

2ND AUDIO

→ON
OFF

PRESS (▲, ▼) TO SELECT
PRESS (MENU) TO END

5 RETURN TO NORMAL SCREEN

Press **MENU** as many times as necessary.

NOTES:

- If a SAP program is received, the SAP audio is recorded on both the Normal and Hi-Fi tracks. The main audio program is not recorded.
- If a non-SAP program is received, the main audio is recorded on both the Hi-Fi and Normal audio tracks.

Instant Timer Recording (ITR)

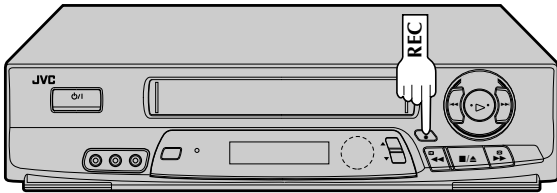

This easy method lets you record for from 30 minutes to 6 hours (selectable in 30-min. increments), and shuts the VCR off after recording is finished.

1 START RECORDING

Press **REC**.

2 ENGAGE ITR MODE

Press **REC** again. **REC** blinks and 0:30 appears on the front display panel.

3 SET RECORDING DURATION

If you want to record for more than 30 minutes, press **REC** to extend the time. Each press extends recording time by 30 minutes.

NOTES:

- You can only perform ITR using the **REC** button on the VCR's front panel.
- After you set the time, the previous display reappears.
- To check remaining recording time, press **REC** once during recording and the remaining time is displayed for about 5 seconds. Be careful not to press again during this 5 seconds, or you'll add 30 more minutes to the recording.

On-Screen Timer Programming

Turn on the TV and select the VCR channel 3 or 4 (or AV mode).

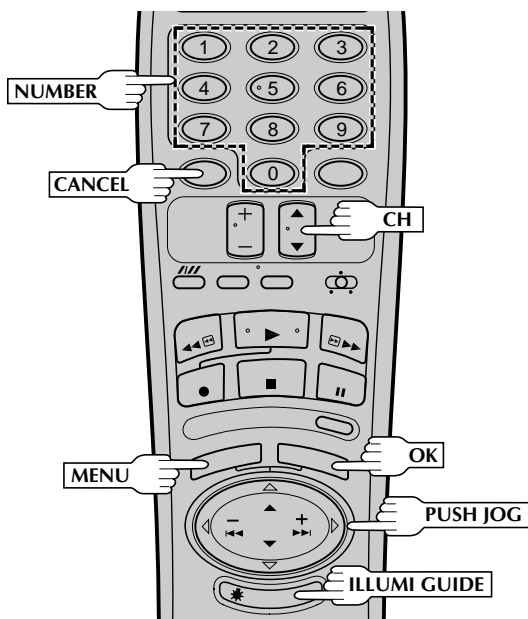
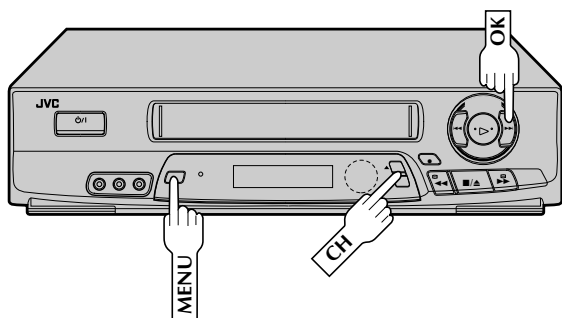

When Using The Illumi-Guide Feature

- Buttons light or blink on the remote control for approximately 10 seconds. If the button or buttons extinguish during timer programming, press **ILLUMI GUIDE** and the button or buttons previously lit or blinking come back on. If the button or buttons do not re-light or start blinking again, press **MENU** as many times as necessary to return to the normal screen and extinguish all illuminated buttons, and re-perform the timer programming procedure from the beginning.
- If for some reason the remote control's signal is not received by the VCR, press **MENU** as many times as necessary to return to the normal screen and extinguish all illuminated buttons, and re-perform the timer programming procedure from the beginning.

You can directly program the VCR's timer to record up to 8 shows, as far as a year in advance. Remember, the clock must be set before you can program the timer (pg. 6). Or you can use the Illumi-Guide feature, where the remote control tells you which button to press next by lighting it up. To use the Illumi-Guide feature, with the **TV/CABLE/VCR** switch set to "VCR", press **ILLUMI GUIDE** before performing step 2. (**MENU**, **REW**, **PLAY**, **FF** light up at this time.)

If you aren't going to use the Illumi-Guide feature, go directly to step 1.

1

LOAD A CASSETTE

Make sure the record safety tab is intact. If not, cover the hole with adhesive tape, then load.

- The VCR comes on, and the counter is reset, automatically.

2

ACCESS ON-SCREEN MENU

Press **MENU** to bring up the Main Menu screen.

- If you are using the Illumi-Guide feature, **OK** blinks when the following buttons are lit: **NUMBER** keys (0 - 9), **PUSH JOG**, **CANCEL** and **MENU**.

3

ACCESS PROGRAM SET SCREEN

Make sure the arrow is to the left of "PROGRAM SET", then press **OK**.

- If you are using the Illumi-Guide feature, **OK** blinks when the following buttons are lit: **NUMBER** keys (0 - 9), **PUSH JOG**, **CANCEL** and **MENU**.

PROGRAM 1	
DATE	--/--
START	--:-- AM
STOP	--:-- AM
CHANNEL	-- SP
PRESS NUMBER KEY(0-9) OR (▲, ▼), THEN (OK) PRESS (MENU) TO END	

4

SELECT PROGRAM NUMBER

Press the appropriate **NUMBER** keys or **CH▲▼** or **PUSH JOG▲▼** to select a vacant program number, then press **OK**. The first time you do this, all numbers will be vacant, so just press **OK** when the screen appears.

- If you are using the Illumi-Guide feature, **OK** blinks when the following buttons are lit: **NUMBER** keys (0 - 9), **PUSH JOG**, **CANCEL** and **MENU**.

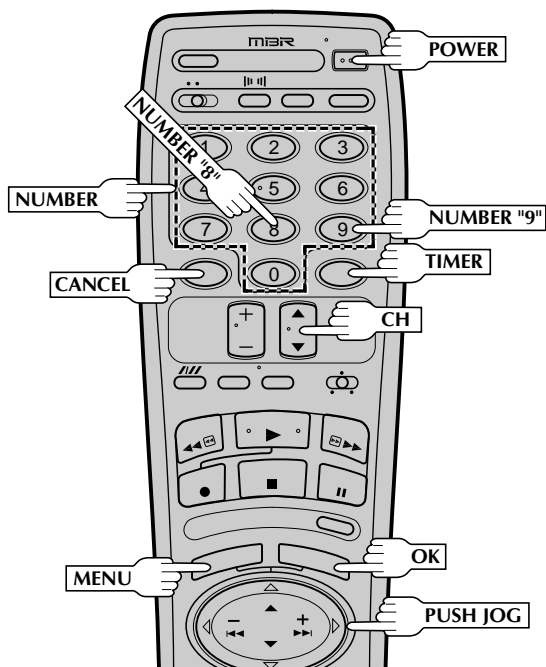
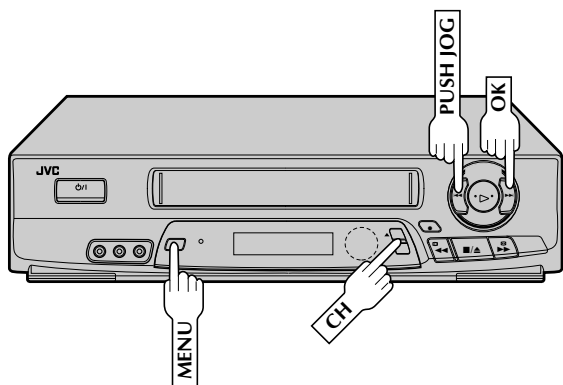

EXAMPLE

If you program the VCR to timer record a show on September 6 on channel 40 from 12:00 noon to 1:00 PM in SP mode, the screen will look like this:

PROGRAM 1	
DATE	9/6 SAT
START	12:00 PM
STOP	1:00 PM
CHANNEL	40 SP
PRESS NUMBER KEY(0-9) OR (▲, ▼), THEN (OK) PRESS (MENU) TO END	

NOTES:

- To disengage the timer before recording starts, press **TIMER** again. Pressing once more re-engages it.
- In case of a power failure after programming, the VCR's memory backup keeps your selections (if the lithium battery is not exhausted).
- If you select "PROGRAM SET" without having set the date and time, an error message appears. Follow its instructions.
- If you enter a start time that has already passed, **ERROR** appears on the screen and flashes.
- Programs that start after midnight must have the next day's date.
- After timer recording is completed, the VCR's power goes off automatically.

5

SET PROGRAM INFORMATION

Press the appropriate **NUMBER** keys to set the date, start/stop time and channel number. Press **CH▲▼** or **PUSH JOG△▽** to set AM/PM and tape speed. Then press **OK** after AM/PM, channel number and tape speed settings. The next setting that can be set begins flashing.

- Any information comprised of 1 digit (except the channel number) should have a "0" entered before it.
- It is possible to set all information using the **CH▲▼** or **PUSH JOG△▽** buttons. (In this case, press **OK** after each setting.)
Do not use the **CH▼** or **PUSH JOG▽** button to set the date.
- If you are using the Illumi-Guide feature, **OK** blinks when the following buttons are lit: **NUMBER** keys (0 - 9), **PUSH JOG**, **CANCEL** and **MENU**.

NOTES:

- If you are using a cable box, enter the cable box channel, not the channel to be recorded. The channel to be recorded must be selected on the cable box. (The cable box channel is the VCR's channel that displays the channels received by the cable box.)
- To timer-record cable or satellite channels through an external tuner connected to the VCR's external input connectors, press the **NUMBER** key "0" so that "AUX" appears instead of a channel number.

** You can record selected programs at the same time every weekday, or once a week. Before entering the month, press **NUMBER** key "8" (DAILY) or "9" (WEEKLY). Either "DAILY" or "WEEKLY" appears. Press again and "DAILY" or "WEEKLY" disappears.

6

MAKE CORRECTIONS

To change any of the settings, press **OK** or **PUSH JOG** <|> until the item you want to change begins blinking. Then set as in step 5.

- If you are using the Illumi-Guide feature, **OK** blinks when the following buttons are lit: **NUMBER** keys (0 - 9), **PUSH JOG**, **CANCEL** and **MENU**.

7

RETURN TO NORMAL SCREEN

Press **MENU** as many times as necessary.

- Press just once to access the Auto Timer screen (pg. 32).
- If you are using the Illumi-Guide feature, all buttons go out.

8

ENGAGE TIMER MODE

Press **TIMER**. The VCR turns off automatically.

- You can program the timer while a regular recording is in progress; the on-screen menu will not be recorded.
- If the end of tape is reached during timer recording, the cassette is automatically ejected.
- When timer-recording cable or satellite channels through an external tuner, be sure to keep the Cable Box or satellite receiver's power ON.

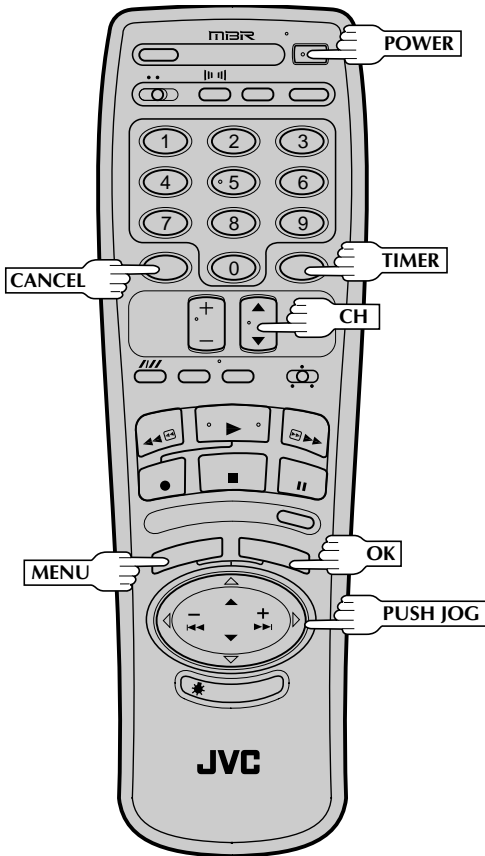
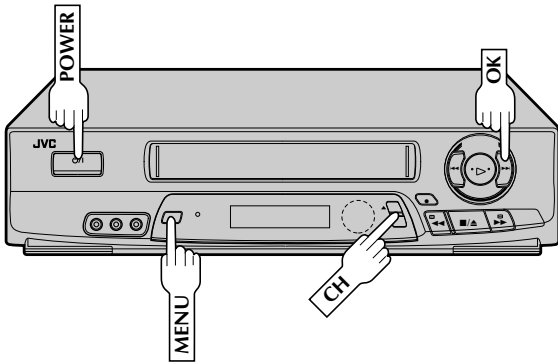

Check And Cancel Programs

1

DISENGAGE TIMER

Press **TIMER**, then press **POWER**.

2

ACCESS PROGRAM SET SCREEN

Press **MENU**, then press **OK**.

3

CHECK PROGRAM INFORMATION

Press **CH▲▼** or **PUSH JOG▲▼** to check the programs in succession.

To Cancel A Program . . .

4

CANCEL A PROGRAM

Press **CANCEL**.

- Repeat steps 3 and 4 as many times as necessary.

5

RETURN TO NORMAL SCREEN

Press **MENU** as many times as necessary. If there are still programs remaining, go to step 6.

6

RE-ENGAGE TIMER

Press **TIMER** again.

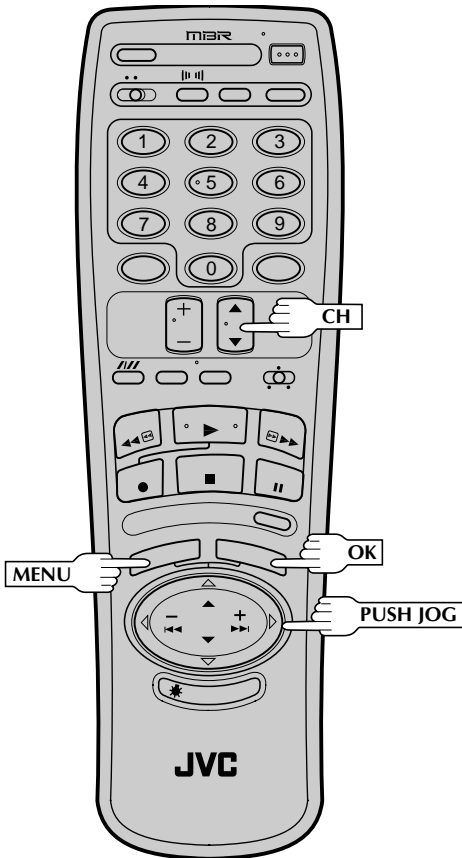
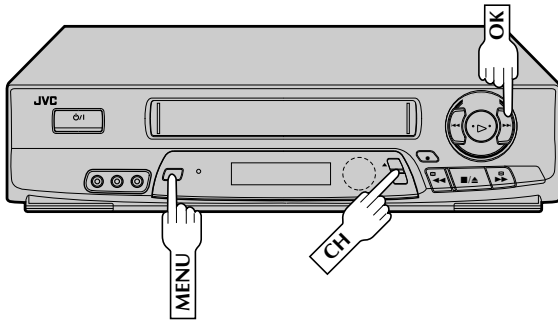

Auto SP/EP Timer

If, when recording in SP mode, there is not enough tape to record the entire program, the VCR automatically switches to EP mode to allow complete recording. This feature is especially handy when recording a program of more than 2 hours in length.

For Example . . .

Recording a program of 140 minutes in length onto a 120-minute tape

Approximately 110 minutes	Approximately 30 minutes
SP mode	EP mode
Total 140 minutes	

Make sure you select "ON" at the Auto SP/EP Timer screen before performing timer programming.

ACCESS MAIN MENU SCREEN

Press **MENU**.

ACCESS FUNCTION SET SCREEN

Place the arrow next to "FUNCTION SET" by pressing **CH▲▼** or **PUSH JOG▲▼**, then press **OK**.

ACCESS AUTO SP/EP TIMER SCREEN

Place the arrow next to "AUTO SP/EP TIMER" by pressing **CH▲▼** or **PUSH JOG▲▼**, then press **OK**.

SELECT MODE

Place the arrow next to your choice ("ON" or "OFF") by press **CH▲▼** or **PUSH JOG▲▼**.

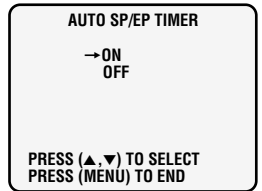

RETURN TO NORMAL SCREEN

Press **MENU** as many times as necessary.

NOTES:

- If you have programmed the VCR to timer-record 2 or more programs, the second program and those thereafter may not fit on the tape if you set the Auto SP/EP Timer mode to "ON". In this case, make sure the mode is not engaged, then set the tape speed manually during timer programming.
- There may be some noise at the point on the tape where the VCR switches from SP to EP mode.
- The Auto SP/EP Timer feature is not available during ITR (Instant Timer Recording), and the feature will not work properly with any tapes other than the following: T-30, T-60, T-90, and T-120.

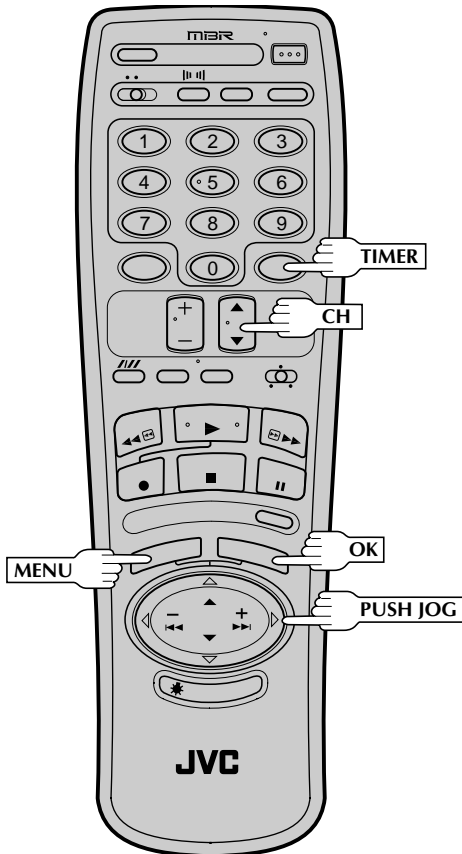
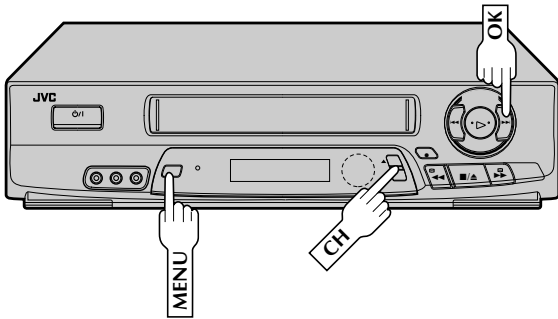

Auto Timer

When the Auto Timer is set to ON the timer is automatically engaged when the VCR's power is turned off and automatically disengaged when the VCR is powered back on.

1 ACCESS MAIN MENU SCREEN

Press **MENU**.

2 ACCESS FUNCTION SET SCREEN

Place the arrow next to "FUNCTION SET" by pressing **CH▲▼** or **PUSH JOG▲▼**, then press **OK**.

3 ACCESS AUTO TIMER SCREEN

Place the arrow next to "AUTO TIMER" by pressing **CH▲▼** or **PUSH JOG▲▼**, then press **OK**. Now skip to step 2 of the procedure below.

Or, during on-screen timer programming ...

1 ACCESS AUTO TIMER SCREEN

In step 7 in the On-Screen Timer Programming procedure (pg. 29), press **MENU**.

2 SELECT MODE

Place the arrow next to your choice ("ON" or "OFF") by pressing **CH▲▼** or **PUSH JOG▲▼**.

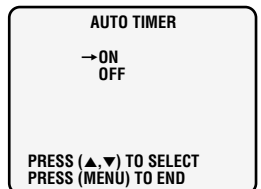

3 RETURN TO NORMAL SCREEN

Press **MENU** as many times as necessary.

NOTE:

For safety, when **AUTO TIMER** is set to "OFF", all other VCR functions are disabled while the Timer mode is engaged. To disengage the timer, press **TIMER**.

Edit To Or From Another VCR

You can use your VCR as the player or the recorder.

MAKE CONNECTIONS

Connect an AV cable (not supplied) between the player's VIDEO OUT and AUDIO OUT connectors and the recorder's VIDEO IN and AUDIO IN connectors.

- When connecting to a monaural VCR, connect your VCR's AUDIO IN/OUT L connector to the AUDIO IN/OUT connector on the monaural VCR.

LOAD CASSETTES

Insert the playback cassette into the player and the cassette to be recorded on into the recorder.

SET RECORDER'S INPUT MODE

Set to AUX. With this VCR, press **NUMBER** key "0" (AU appears on the front display panel in place of a channel number).

NOTE:

When using this VCR as the recorder, make sure to select "FRONT" or "REAR" (depending on which input connectors you use) at the Aux Input Screen. (To select the correct AUX input connector, follow steps 4, 5, 9 – 11 from the "Edit From A Camcorder" section, pg. 34.)

START PLAYER

Set to its play mode.

START RECORDER

Set to its record mode.

1
2
3
4
5

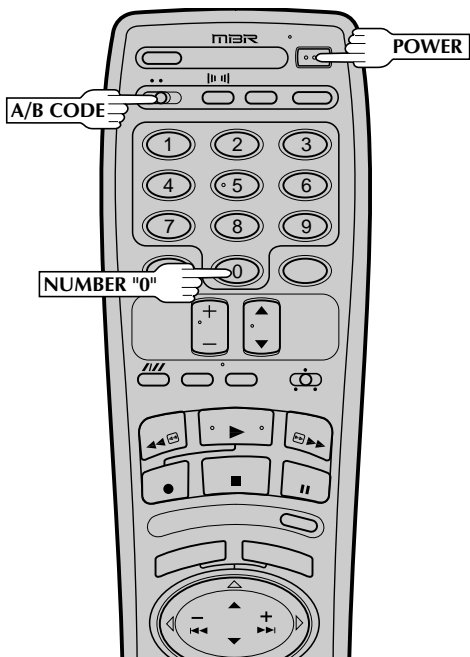
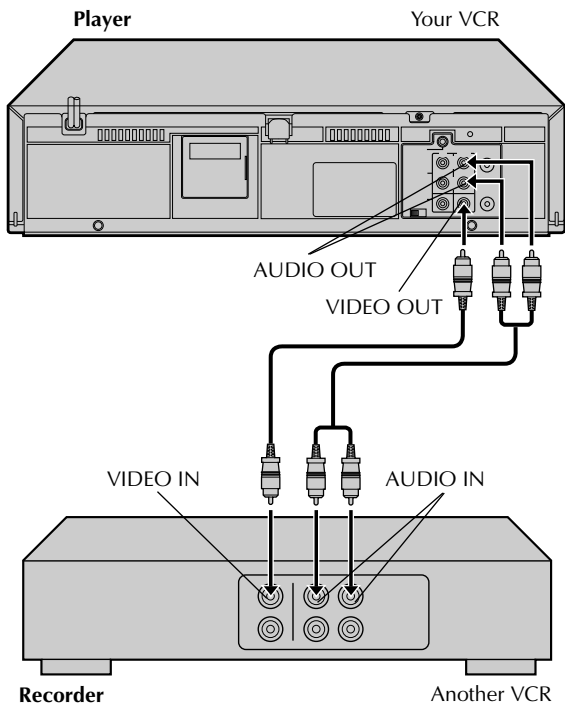

Control Two JVC VCRs

The supplied remote control is capable of controlling two JVC VCRs independently using the **A/B CODE** switch. You can set this VCR so it responds to remote commands only when the switch is set to **B**, and another VCR so it responds to commands when the switch is set to **A**. The switch is preset to **A** because this VCR normally responds to A-code signals. You can easily modify this VCR to accept B-code commands.

- 1 Unplug the VCR's power cord from the AC outlet.
- 2 Set the **A/B CODE** switch on the remote control to **B**.
- 3 Plug the VCR's power cord back into the AC outlet.
- 4 Turn the VCR's power back on by pressing **POWER** on the remote.

The VCR will now respond only to B-code commands.

Edit From A Camcorder

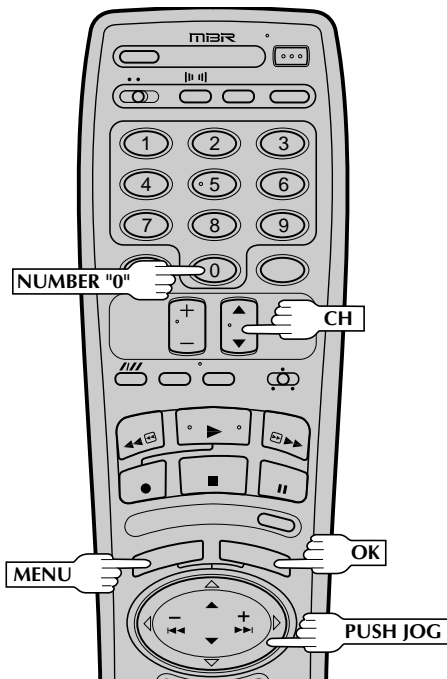
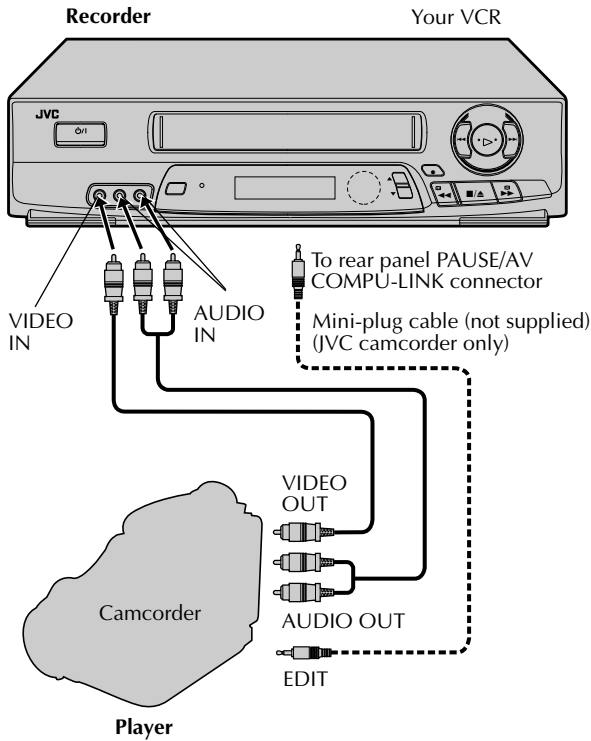

You can use a camcorder as the player and your VCR as the recorder.

1 MAKE CONNECTIONS

Connect an AV cable (not supplied) between the camcorder's VIDEO OUT and AUDIO OUT connectors and your VCR's VIDEO IN and AUDIO IN connectors.

- When a Master Edit Control-equipped JVC camcorder is used, the camcorder is capable of controlling your VCR. The Mini-plug cable is a mono 3.5 mm mini-plug to mono 3.5 mm mini-plug connector.
- When using a monaural camcorder, connect its AUDIO OUT connector to the AUDIO IN L connector on your VCR.

2 LOAD A CASSETTE

Insert the cassette to be recorded on into your VCR and the playback cassette into the camcorder.

3 SET RECORDER'S INPUT MODE

Press **NUMBER** key "0" to set your VCR to AUX.

4 ACCESS MAIN MENU SCREEN

Press **MENU**.

5 ACCESS FUNCTION SET SCREEN

Press **CH▲▼** or **PUSH JOG△▽** to place the arrow next to "FUNCTION SET", then press **OK**.

If you're using a JVC Master Edit Control-equipped camcorder — step 6

If not — step 9

6 ACCESS SPECIAL FUNCTION SCREEN

Press **CH▲▼** or **PUSH JOG△▽** to place the arrow next to "SPECIAL FUNCTION", then press **OK**.

7 SELECT MODE

Press **CH▲▼** or **PUSH JOG△▽** to place the arrow next to "PAUSE".

SPECIAL FUNCTION

→ PAUSE
AV COMPU-LINK

PRESS (▲, ▼) TO SELECT
PRESS (MENU) TO END

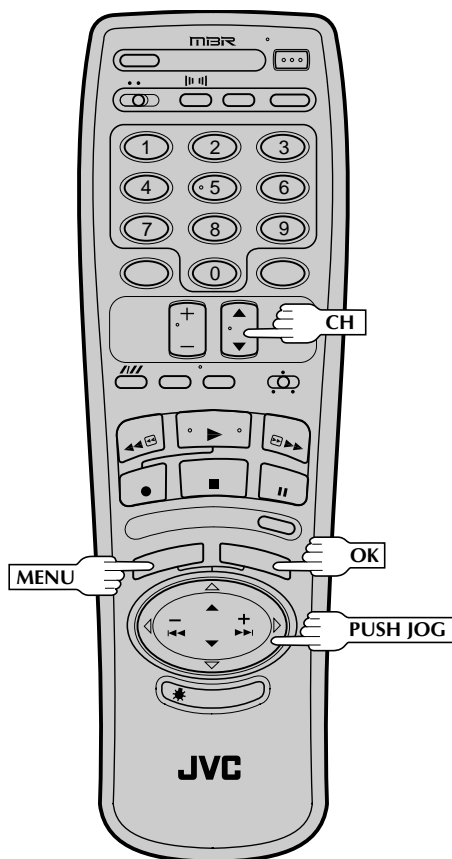
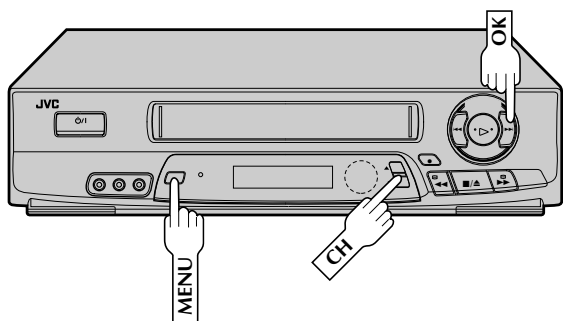

8 RETURN TO FUNCTION SET SCREEN

Press **MENU**.

9 ACCESS AUX INPUT SCREEN

Press **CH▲▼** or **PUSH JOG▲▼** to place the arrow next to "AUX INPUT", then press **OK**.

10 SELECT INPUT

If you are connecting the AV cable to the AV connectors on the front of the VCR, place the arrow next to "FRONT" by pressing **CH▲▼** or **PUSH JOG▲▼**. If you are connecting the AV cable to the AV connectors on the back of the VCR, place the arrow next to "REAR" by pressing **CH▲▼** or **PUSH JOG▲▼**.

AUX INPUT
→ FRONT
REAR

PRESS (▲, ▼) TO SELECT
PRESS (MENU) TO END

11 RETURN TO NORMAL SCREEN

Press **MENU** as many times as necessary.

12 START PLAYER

Set the camcorder to its play mode.

13 START RECORDER

Set your VCR to its record mode.

- If you are using a Master Edit Control-equipped JVC camcorder, it can put the recorder automatically into Record mode. (Refer to camcorder's instruction manual.)

TV Multi-Brand Remote Control

The VCR's remote control can control several functions on JVC remote control TVs and on the brands of remote control TVs listed below.

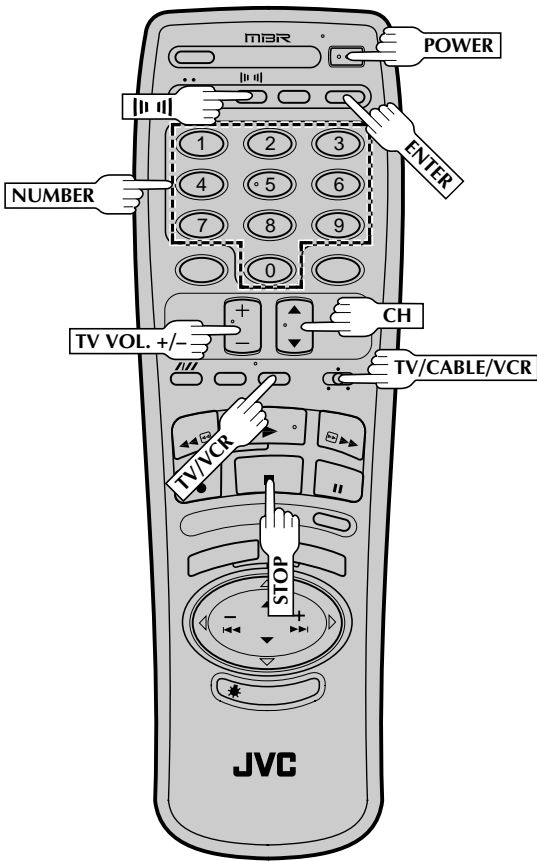

1 TURN ON THE TV

Turn the power on using the TV's remote control.

2 SET REMOTE CONTROL MODE

Set the TV/CABLE/VCR switch on the VCR's remote control to TV.

3 SET TV BRAND CODE

Refer to the chart below. While holding down **POWER** on the VCR's remote control, enter your TV's brand code using the **NUMBER** keys, then press **STOP**. Follow the example shown at bottom left.

- Once you have set the remote control to operate the TV, you don't have to repeat this step until you replace your remote control's batteries.
- GRADIENTE has four codes. If the TV does not function with one code, try entering another.

4 OPERATE TV

First, press **POWER** on the remote to see if the TV's power goes off as it should. If it does, try other operations.

- The **POWER**, **TV/VCR**, **CH▲▼**, **TV VOL. +/-** and **NUMBER** keys on the remote can all be used to operate the TV. *For some brands of TV, you must press **ENTER** after having pressed the **NUMBER** keys.
- If you have a JVC TV equipped with Hyper Surround or Live Effex, the **|||** button may work to operate it.
- To return the remote to VCR control, set the **TV/CABLE/VCR** switch to VCR.

NOTE:

Depending on the kind of TV, there may be cases where some or all functions cannot be operated using the remote control.

TV BRAND NAME	BRAND CODE
JVC	01
GRADIENTE	02, 11, 12, 16
PHILIPS	03
CCE	03
SANYO	04
PHILICO/HITACHI	05
SHARP	06
TOSHIBA	07
MITSUBISHI	08
PHILICO/DAEWOO	09
SAMSUNG	10
GOLDSTAR	11
RCA	12
PANASONIC	13
GRUNDIG	14
SONY	15
NEC	16
PHILICO	17
NOBLEX	18

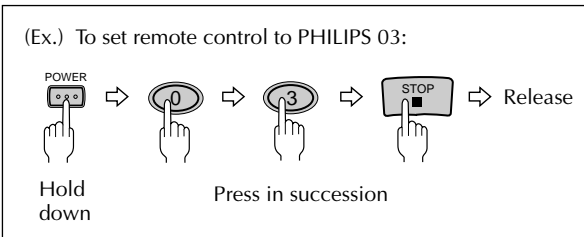

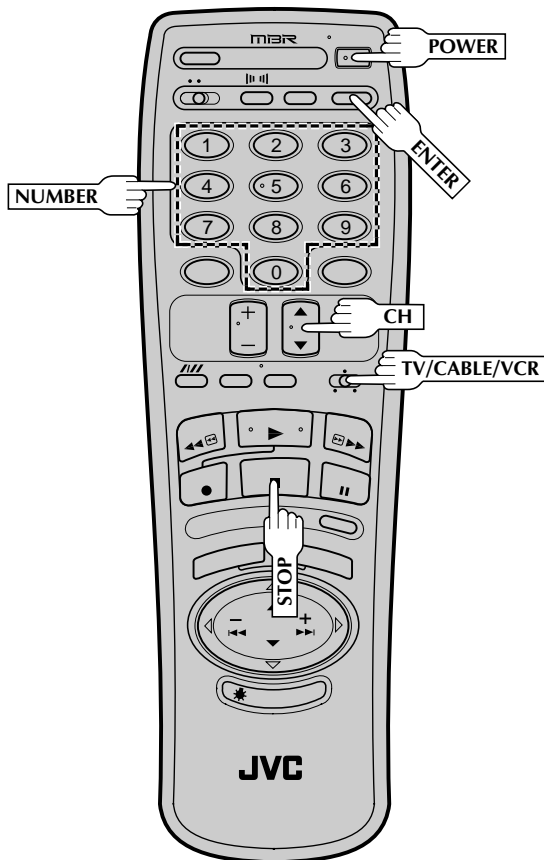

Cable Box Multi-Brand Remote Control

The VCR's remote control can control functions on the brands of cable boxes listed below. Some cable box brands have more than one code. If your cable box does not function with a specified code, try other codes.

- 1 TURN ON THE CABLE BOX**
Turn the power on using the cable box's remote control.
- 2 SET REMOTE CONTROL MODE**
Set the **TV/CABLE/VCR** switch on the VCR's remote control to **CABLE**.
- 3 ENTER CABLE BOX BRAND**
While holding down **POWER** on the VCR's remote control, use the **NUMBER** keys to enter the cable box brand number from the chart at bottom left and then press **STOP**.
Follow the example shown below.
 - Once you have set the remote control to operate the cable box, you don't have to repeat this step until you replace the remote control's batteries.
- 4 OPERATE CABLE BOX**
First, press **POWER** to see if the cable box's power goes off as it should. If it does, try other functions (**CH▲▼** and the **NUMBER** keys can be used to operate the cable box).
 - For some brands of cable box, you must press **ENTER** after having pressed the **NUMBER** keys.
 - To return the remote to VCR control, set the **TV/CABLE/VCR** switch to **VCR**.

NOTES:

- Depending on the kind of cable box, there may be cases where some or all functions cannot be operated using the remote control.
- It's not possible to set the remote control for both your cable box and your satellite receiver at the same time; you can only set the remote control to the brand of either one.
- You have to subscribe to a cable service to receive cable channels.

CABLE BOX BRAND NAME	BRAND CODE
CURTIS	08, 09
GEMINI	17
GENERAL INSTRUMENTS	10, 11, 12, 13, 14, 15, 16, 17
JERROLD	10, 11, 12, 13, 14, 15, 16, 17
PANASONIC	03, 04, 05
RCA	03, 04, 05
SAMSUNG	17, 18
SCIENTIFIC ATLANTA	08, 09
SL MARX	17, 18
SPRUCER	03, 04, 05
TELEVIEW	17, 18
TOCOM	01, 02
VIDEOWAY	06, 07
ZENITH	06, 07

(Ex.) To set remote control to TOCOM 01:

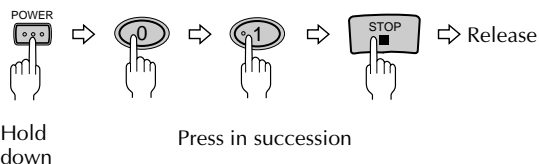

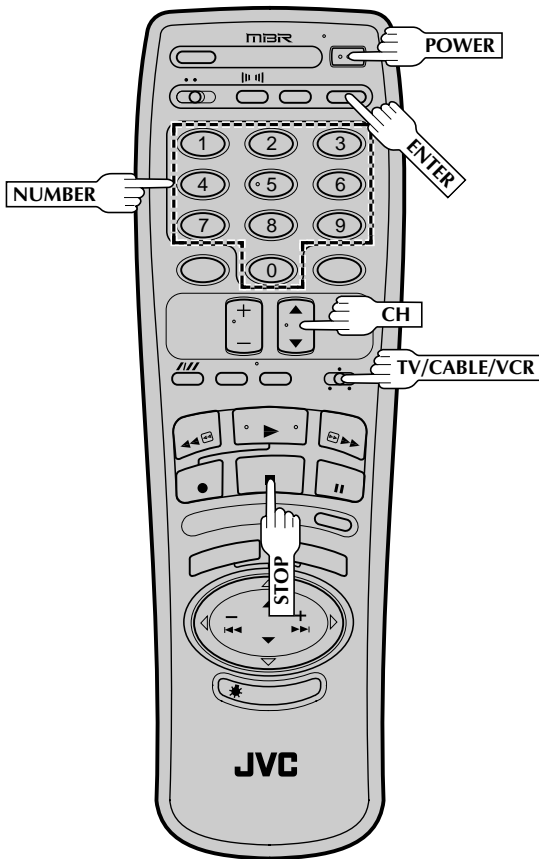

Satellite Receiver Multi-Brand Remote Control

The VCR's remote control can control functions on the brands of satellite receivers listed below.

1 TURN ON THE SATELLITE RECEIVER

Turn the power on using the satellite receiver's remote control.

2 SET REMOTE CONTROL MODE

Set the TV/CABLE/VCR switch on the VCR's remote control to CABLE.

3 ENTER SATELLITE RECEIVER BRAND

While holding down **POWER** on the VCR's remote control, use the **NUMBER** keys to enter the satellite receiver brand number from the chart below and then press **STOP**.

Follow the example shown at bottom left.

- Once you have set the remote control to operate the satellite receiver, you don't have to repeat this step until you replace the remote control's batteries.

4 OPERATE SATELLITE RECEIVER

First, press **POWER** to see if the satellite receiver's power goes off as it should. If it does, try other functions (**CH**▲▼ and the **NUMBER** keys can be used to operate the satellite receiver).

- For some brands of satellite receiver, you must press **ENTER** after having pressed the **NUMBER** keys.
- To return the remote to VCR control, set the **TV/CABLE/VCR** switch to VCR.

NOTES:

- Depending on the kind of satellite receiver, there may be cases where some or all functions cannot be operated using the remote control.
- It's not possible to set the remote control for both your cable box and your satellite receiver at the same time; you can only set the remote control to the brand of either one.
- You have to subscribe to a satellite broadcaster to receive satellite channels.

(Ex.) To set remote control to RCA 80:

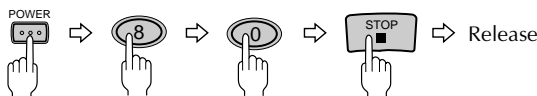

Hold down

Press in succession

SATELLITE BRAND NAME	BRAND CODE
RCA (DSS)	80
SONY (DSS)	81
PRIMESTAR	90

PLAYBACK

Q. What happens if the end of the tape is reached during playback or search?

A. The tape is automatically rewound to the beginning.

Q. Can the VCR indefinitely remain in the still mode?

A. No. It stops automatically after 5 minutes to protect the heads.

Q. During search, slow, still and frame-by-frame playback, I can't hear any audio. What's the problem?

A. This is normal.

Q. During search, still and frame-by-frame playback, the picture is intermittent. What's the cause?

A. Picture loss occurs when these types of playback are attempted with a tape recorded in LP mode. Pressing **PLAY** to return to normal playback will restore the picture.

Q. When returning from multi-speed search to normal playback, the picture is disturbed. Should I be concerned about this?

A. No, it is normal.

Q. Noise bars appear during multi-speed search. What's the problem?

A. This is normal.

Q. Other than preventing further recording, what effect does removing the safety tab have?

A. It disables marking of index codes.

Q. Sometimes, during Index Search, the VCR can't find the program I want to see. Why not?

A. There may be index codes too close together.

Q. During playback, on-screen operational indicators sometimes jitter. Why does this happen?

A. If the condition of the tape being played back is not good, jittering of the video (including on-screen indicators) may occur.

RECORDING

Q. When I pause and then resume a recording, the end of the recording before the pause is overlapped by the new recording. Why does this happen?

A. This is normal. It reduces distortion at the pause and resume points.

Q. Can the VCR indefinitely remain in the Record-Pause mode?

A. No. The VCR automatically goes to its Stop mode after 5 minutes to protect the heads. When paused during Instant Timer Recording (ITR), the VCR shuts off automatically after 5 minutes.

Q. What happens if the tape runs out during recording?

A. The VCR automatically rewinds it to the beginning.

TIMER RECORDING

Q. REC and TIMER remain lit on the front display panel. Is there a problem?

A. No. This is a normal condition for a timer recording in progress.

Q. Can I program the timer while I'm watching a tape or a TV broadcast?

A. You won't see the picture as it is replaced by the on-screen menu, but the audio from the program or tape you're viewing is present.

Before requesting service for a problem, use this chart and see if you can repair the trouble yourself. Small problems are often easily corrected, and this can save you the trouble of sending your VCR off for repair.

POWER

SYMPTOM	POSSIBLE CAUSE	CORRECTIVE ACTION
1. The power won't come on.	<ul style="list-style-type: none"> • The power cord is disconnected. 	Connect the power cord.
2. The clock works, but the VCR's power won't come on.	<ul style="list-style-type: none"> • The TIMER mode is engaged with Auto Timer set to "OFF" (☞ pg. 32). 	Press TIMER to disengage.
3. The remote control won't function.	<ul style="list-style-type: none"> • The batteries are discharged. • The A/B CODE switch is in the wrong position. • The TV/CABLE/VCR switch is in the wrong position. 	Replace the dead batteries with new ones. Re-perform the A/B Code setting (☞ pg. 33). Set the switch to the position corresponding with the unit you want to operate.

TAPE TRANSPORT

SYMPTOM	POSSIBLE CAUSE	CORRECTIVE ACTION
1. The cassette gets stuck partway during loading, and is ejected.	<ul style="list-style-type: none"> • The cassette was inserted incorrectly. 	Make sure the window side is up, the rear label side is facing you and the arrow on the front of the cassette is pointing towards the VCR. Then insert the cassette.
2. The tape stops during rewind or fast forward.	<ul style="list-style-type: none"> • The Counter Memory indicator ("M") is lit on the front display panel. 	Press C.MEMORY to disengage the Counter Memory mode and extinguish the indicator.

PLAYBACK



SYMPTOM	POSSIBLE CAUSE	CORRECTIVE ACTION
1. The tape is running but the picture won't appear.	<ul style="list-style-type: none"> • If you're using the RF OUT connection (☞ pg. 4), the channel selector on the TV is set incorrectly. • If you're using the AV connection (☞ pg. 4), the TV receiver is set to the wrong mode. 	Set the channel selector to channel 3 or 4. Set the TV receiver to its AV mode.
2. Noise appears during visual search.	<ul style="list-style-type: none"> • This is normal. 	
3. Breaks are noticeable in Hi-Fi soundtrack.	<ul style="list-style-type: none"> • Automatic tracking is engaged. 	Engage and adjust tracking manually (☞ pg. 14).
4. The playback picture is blurred or interrupted, even though TV broadcasts are clear.	<ul style="list-style-type: none"> • The video heads may be dirty. 	The heads must be cleaned. Consult your JVC dealer.
5. The Hi-Fi soundtrack cannot be heard.	<ul style="list-style-type: none"> • The AUDIO MONITOR option at the Function Set screen was set incorrectly. 	Set AUDIO MONITOR to "HI-FI" (☞ pg. 16).

RECORDING

SYMPTOM	POSSIBLE CAUSE	CORRECTIVE ACTION
1. Recording won't start.	<ul style="list-style-type: none"> • There's no cassette loaded. • The loaded cassette has had its record safety tab removed. 	Insert a cassette. Remove the cassette and cover the hole with adhesive tape, or load a cassette on which the record safety tab is intact.

2. TV broadcasts won't record properly.	<ul style="list-style-type: none"> ● The VCR has been set to its AUX mode by mistake. 	Set the VCR to the appropriate channel.
3. Tape-to-tape editing won't work.	<ul style="list-style-type: none"> ● The VCRs or the camcorder and the VCR have been incorrectly connected. ● The power to one or more of the units has not been turned on. ● The recorder's input mode has been set incorrectly. 	Refer to the directions and the illustration under "Edit To Or From Another VCR" (☞ pg. 33) or "Edit From A Camcorder" (☞ pg. 34) and properly connect the units. Make sure the power to all units is on. Set the recorder's input mode to AUX and select "FRONT" or "REAR" at the Aux Input Screen (☞ pg. 35).

TIMER RECORDING

SYMPTOM	POSSIBLE CAUSE	CORRECTIVE ACTION
1. Timer recording won't work.	<ul style="list-style-type: none"> ● The clock and/or the timer have been set incorrectly. ● The timer is not engaged. ● The VCR has not been set up properly. 	Check or re-perform the clock/timer settings to ensure correctness. Press TIMER and check to make sure that TIMER appears on the front display panel. Re-perform the set-up procedures.
2. On-screen timer programming won't work.	<ul style="list-style-type: none"> ● Timer recording is in progress. 	Timer programming can't be performed when timer recording is in progress. Wait until it finishes.
3. TIMER and  on the front display panel won't stop blinking.	<ul style="list-style-type: none"> ● The timer is engaged but there's no cassette loaded. 	Load a cassette with the record safety tab intact, or with the hole covered with adhesive tape.
4. The cassette is automatically ejected, and TIMER and  on the front display panel won't stop blinking.	<ul style="list-style-type: none"> ● The loaded cassette has had its record safety tab removed. 	Remove the cassette and cover its hole with adhesive tape, or replace it with a cassette on which the safety tab is intact.
5. TIMER blinks for 10 seconds and the timer mode is disengaged.	<ul style="list-style-type: none"> ● TIMER has been pressed when there are no programs in memory, or the timer record program information has not been programmed correctly. 	Check the programmed data and re-program as necessary, then press TIMER again.
6. The cassette is automatically ejected, the power shuts off and TIMER and  won't stop blinking.	<ul style="list-style-type: none"> ● The end of tape was reached during timer recording. 	The program may not have been recorded in its entirety. Next time make sure you have enough time on the tape to record the entire program.

OTHER PROBLEMS

SYMPTOM	POSSIBLE CAUSE	CORRECTIVE ACTION
1. When scanning channels, some of them are skipped over.	<ul style="list-style-type: none"> ● Those channels have been preset to be skipped. 	If you need the skipped channels, restore them (☞ pg. 10).
2. The channel can't be changed.	<ul style="list-style-type: none"> ● Recording is in progress. 	Press PAUSE to pause the recording, change channels, then press PLAY to resume recording.
3. The remote control won't operate my TV or cable box or satellite receiver.	<ul style="list-style-type: none"> ● The remote control brand setting is incorrect. 	Re-set the remote control to the correct brand. (☞ pg. 36 – 38)
4. "--:--" is displayed on the front display panel after a power outage.	<ul style="list-style-type: none"> ● The lithium battery is exhausted. 	Replace the lithium battery with a new one. (☞ pg. 5)

ATTENTION:

This recorder contains microcomputers. External electronic noise or interference could cause malfunctioning. In such cases, switch the power off and unplug the power cord. Then plug it in again and switch power on. Take out the cassette. After checking the cassette, operate the unit as usual.

FRONT VIEW

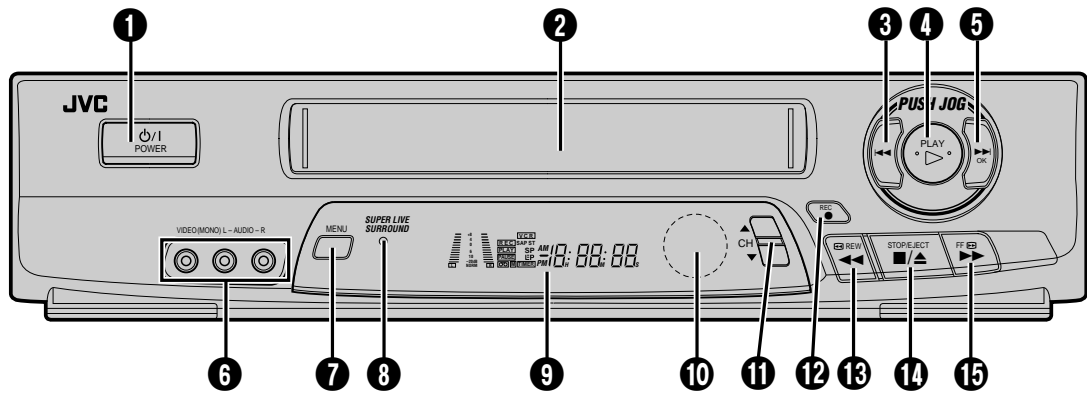

- ❶ POWER $\text{\textcircled{P}}$ /I Button (☞ pg. 5)
- ❷ Cassette Loading Slot
- ❸ PUSH JOG ◀◀ Button (☞ pg. 13)
- ❹ PLAY Button (☞ pg. 11)
- ❺ PUSH JOG ▶▶ Button (☞ pg. 13)
OK Button (☞ pg. 6)
- ❻ VIDEO/AUDIO Input Connector (☞ pg. 34)
- ❼ MENU Button (☞ pg. 6)
- ❽ SUPER LIVE SURROUND indicator (☞ pg. 14)
- ❾ Front Display Panel (☞ pg. 43)
- ❿ Remote Control Sensor
- ⓫ Channel ▲▼ Buttons (☞ pg. 6)
- ⓬ Record [REC] Button (☞ pg. 12)
- ⓭ Rewind [REW] Button (☞ pg. 11)
- ⓮ STOP/EJECT Button (☞ pg. 11)
- ⓯ Fast-Forward [FF] Button (☞ pg. 11)

REAR VIEW

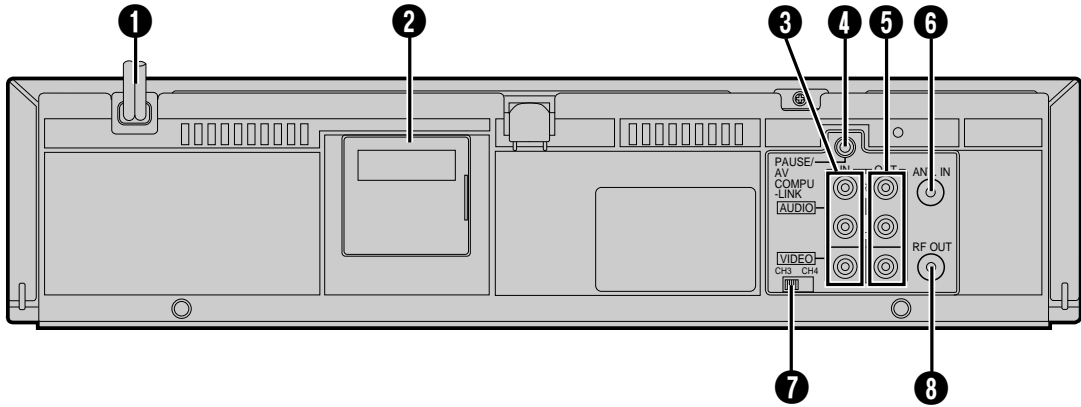

- ❶ Power Cord (☞ pg. 4)
- ❷ Lithium Battery Compartment (☞ pg. 5)
- ❸ VIDEO/AUDIO Input Connectors (☞ pg. 33)
- ❹ PAUSE/AV COMPU LINK Connector
 - Remote PAUSE Connector (☞ pg. 34)
 - AV COMPU LINK Connector (☞ pg. 20)
- ❺ VIDEO/AUDIO Output Connectors (☞ pg. 4)
- ❻ ANT. IN Connector (☞ pg. 4)
- ❼ Channel 3/4 Switch (☞ pg. 4)
- ❽ RF OUT Connector (☞ pg. 4)

FRONT DISPLAY PANEL

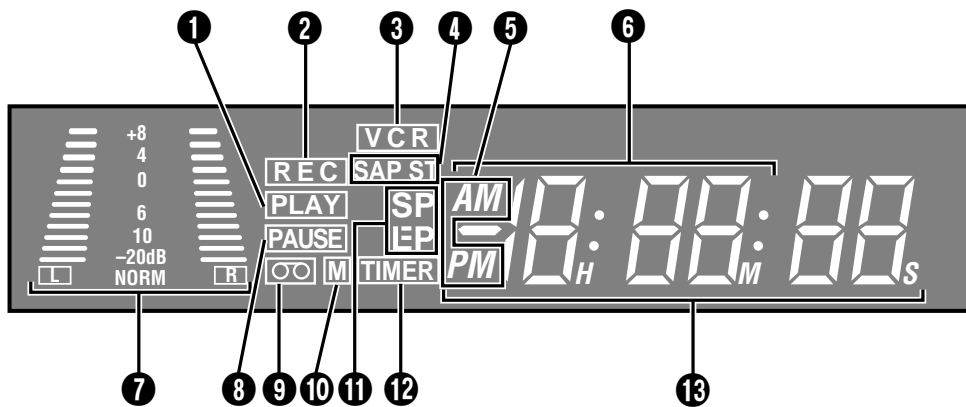

- ❶ Play Mode Indicator (☞ pg. 11)
- ❷ Recording Mode Indicator (☞ pg. 12)
- ❸ VCR Mode Indicator (☞ pg. 25)
- ❹ Multichannel TV Sound Indicators (☞ pg. 26)
- ❺ AM/PM Indicators (☞ pg. 7)
- ❻ Clock Display (☞ pg. 7)
- ❼ Audio Level Meter
- ❽ Pause Mode Indicator (☞ pg. 12)
- ❾ "Cassette Loaded" Mark
- ❿ Counter Memory Mark (☞ pg. 19)
- ⓫ Tape Speed Indicators (☞ pg. 12)
- ⓬ Timer Mode Indicator (☞ pg. 29)
- ⓭ Channel Display ["AU" for AUX mode] (☞ pg. 33)
- Counter Display (☞ pg. 19)

REMOTE CONTROL (Provided)

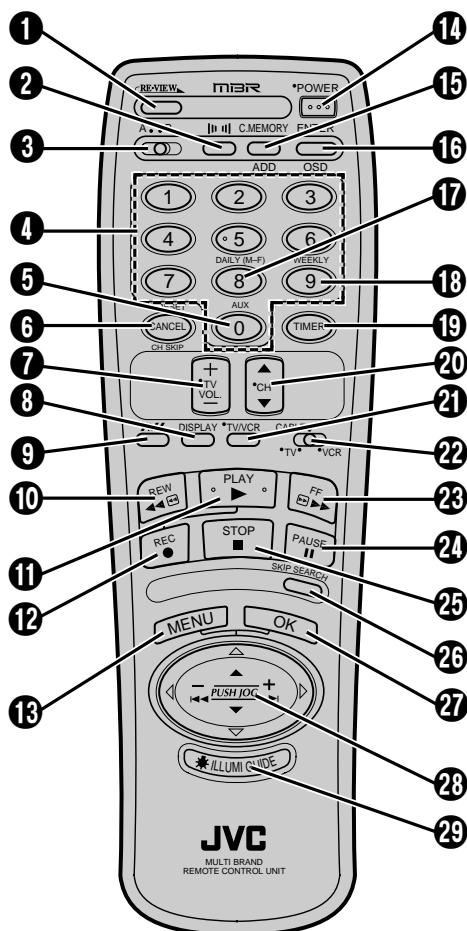

- 1 Instant REVIEW Button (☞ pg. 19)
- 2 Super Live Surround Button (☞ pg. 14)
- 3 A/B Code Select Switch (☞ pg. 33)
- 4 NUMBER Buttons (☞ pg. 12)
- 5 "AUX" Mode Select Button (☞ pg. 33)
- 6 CANCEL Button (☞ pg. 30)
- 7 Counter [C.] RESET (☞ pg. 19)
- 8 Channel [CH.] SKIP Button (☞ pg. 10)
- 9 Volume [TV VOL.] +/- Buttons (☞ pg. 36)
- 10 DISPLAY Button (☞ pg. 19)
- 11 Recording Speed [SP/EP] Button (☞ pg. 12)
- 12 Rewind [REW] Button (☞ pg. 11)
- 13 PLAY Button (☞ pg. 11)
- 14 Record [REC] Button (☞ pg. 12)
- 15 MENU Button (☞ pg. 6)
- 16 POWER \downarrow/\uparrow Button (☞ pg. 5)
- 17 Counter [C.] MEMORY Button (☞ pg. 19)
- 18 ADD Button (☞ pg. 10)
- 19 ENTER Button (☞ pg. 12)
- 20 On-Screen Display [OSD] Button (☞ pg. 17)
- 21 DAILY Timer Recording Button (☞ pg. 29)
- 22 WEEKLY Timer Recording Button (☞ pg. 29)
- 23 TIMER Button (☞ pg. 29)
- 24 Channel [CH] ▲▼ Buttons (☞ pg. 6)
- 25 TV/VCR Button (☞ pg. 25)
- 26 TV/CABLE/VCR Switch (☞ pg. 36)
- 27 Fast-Forward [FF] Button (☞ pg. 11)
- 28 PAUSE Button (☞ pg. 12)
- 29 STOP Button (☞ pg. 11)
- 30 SKIP SEARCH Button (☞ pg. 18)
- 31 OK Button (☞ pg. 6)
- 32 PUSH JOG Button (☞ pg. 6)
- 33 ILLUMI GUIDE Button (☞ pg. 28)

Buttons with a small dot on the left side of the name can also be used to operate your TV: **POWER**, **TV VOL. +/-**, **CH ▲▼**, **TV/VCR**. Use these buttons with the **TV/CABLE/VCR** switch set to "TV".

Installing Batteries

- 1 Open the battery compartment cover.
- 2 Insert 2 "AA"-size batteries (provided) in the direction indicated under the battery cover.
- 3 Replace the cover.

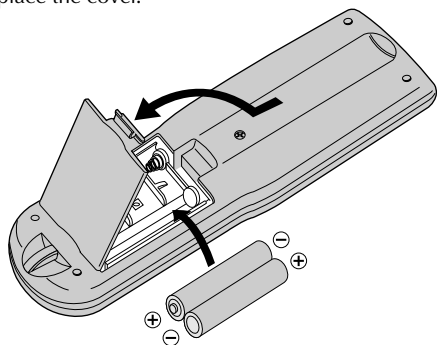

How To Use

The remote control can operate most of your VCR's functions.

- 1 Point the remote control toward the sensor window.
- 2 Press the appropriate operation button.
- 3 The maximum operating distance of the remote control is about 8 m.

NOTES:

- This remote control can also operate various brands of TVs, Cable Boxes and Satellite Receivers. For instructions, ☞ pg. 36 - 38.
- If the remote control doesn't work properly, remove its batteries, wait a short time, replace the batteries and then try again.

GENERAL

Power requirement	: AC 110 – 220 V \sim , 50/60 Hz
Power consumption	: 21 W
Temperature	
Operating	: 5°C to 40°C (41°F to 104°F)
Storage	: -20°C to 60°C (-4°F to 140°F)
Operating position	: Horizontal only
Dimensions (W x H x D)	: 400 x 94 x 276 mm (15-3/4" x 3-3/4" x 10-7/8")
Weight	: 3.6 kg (8.0 lbs)
Format	: VHS NTSC standard
Maximum recording time	
SP	: 210 min. with ST-210 video cassette
EP	: 630 min. with ST-210 video cassette

VIDEO/AUDIO

Signal system	: NTSC-type color signal and EIA monochrome signal, 525 lines/60 fields
Recording/ Playback system	: DA-4 (Double Azimuth) head helical scan system
Signal-to-noise ratio	: 45 dB
Horizontal resolution	: 240 lines
Frequency range	
Normal audio	: 70 Hz to 10,000 Hz
Hi-Fi audio	: 20 Hz to 20,000 Hz
Input/Output	: RCA connectors (IN x 2, OUT x 1)

TUNER

Tuning system	: Frequency-synthesized tuner
Channel coverage	
VHF	: Channels 2–13
UHF	: Channels 14–69
CATV	: 113 Channels
RF output	: Channel 3 or 4 (switchable; preset to Channel 3 when shipped) 75 ohms, unbalanced

TIMER

Clock reference	: Quartz
Memory backup	: Lithium battery
Program capacity	: 1-year programmable timer/ 8 programs

ACCESSORIES

Provided accessories	: RF cable, Infrared remote control unit, Lithium battery CR2025, "AA" battery x 2, Conversion plug
----------------------	---

Specifications shown are for SP mode unless otherwise specified. E. & O.E. Design and specifications subject to change without notice.

Failure to heed the following precautions may result in damage to the VCR, remote control or video cassette.

- DO NOT** place the VCR . . .
 - ... in an environment prone to extreme temperatures or humidity.
 - ... in direct sunlight.
 - ... in a dusty environment.
 - ... in an environment where strong magnetic fields are generated.
 - ... on a surface that is unstable or subject to vibration.
- DO NOT** block the VCR's ventilation openings.
- DO NOT** place heavy objects on the VCR or remote control.
- DO NOT** place anything which might spill on top of the VCR or remote control.
- AVOID** violent shocks to the VCR during transport.

**MOISTURE CONDENSATION

Moisture in the air will condense on the VCR when you move it from a cold place to a warm place, or under extremely humid conditions—just as water droplets form on the surface of a glass filled with cold liquid. Moisture condensation on the head drum will cause damage to the tape. In conditions where condensation may occur, keep the VCR's power turned on for a few hours to let the moisture dry.

**ABOUT HEAD CLEANING

Accumulation of dirt and other particles on the video heads may cause the playback picture to become blurred or interrupted. Be sure to contact your nearest JVC dealer if such troubles occur.

